

Round Cube DOUBLE 2.4 / 2.6

Construction guide

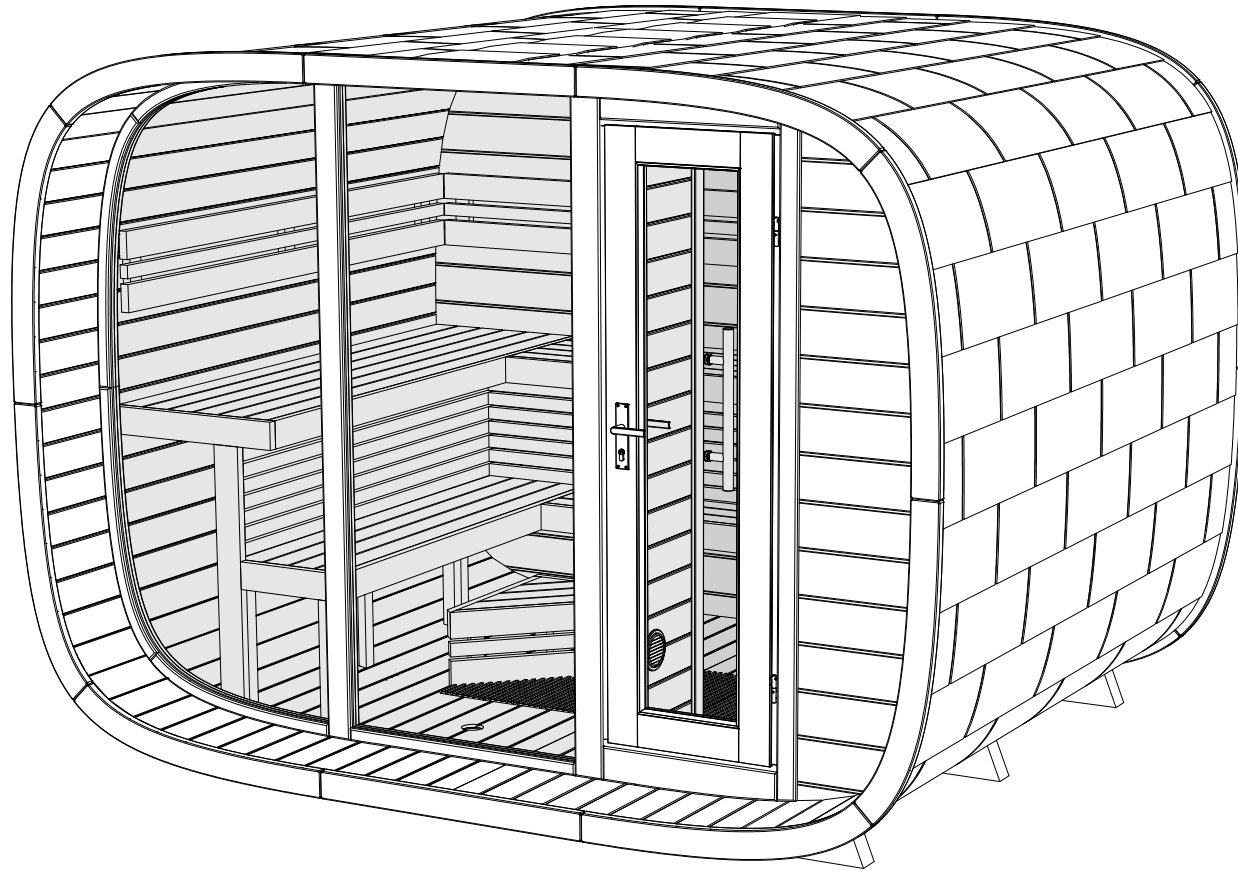

Check the parts for completeness before assembly!

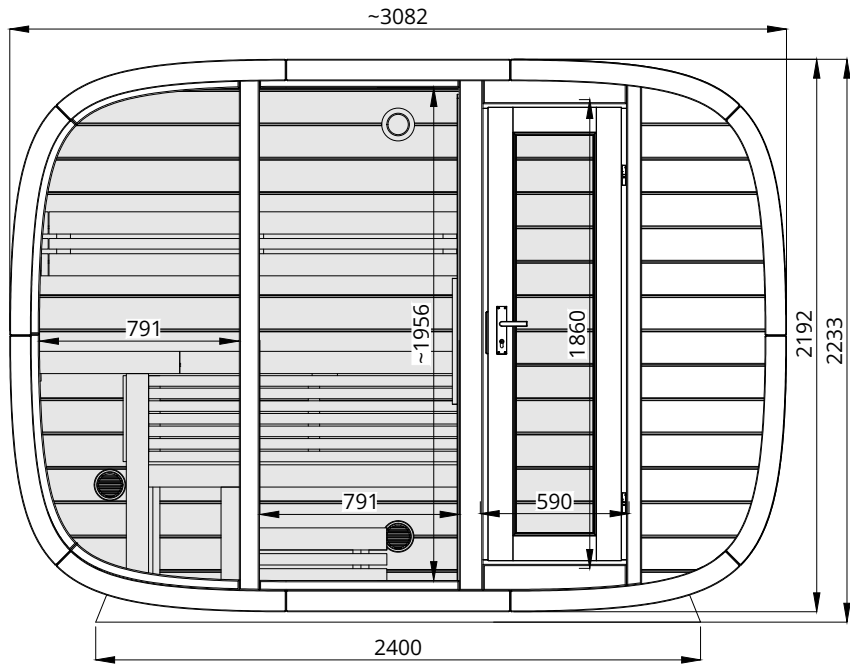

Front view

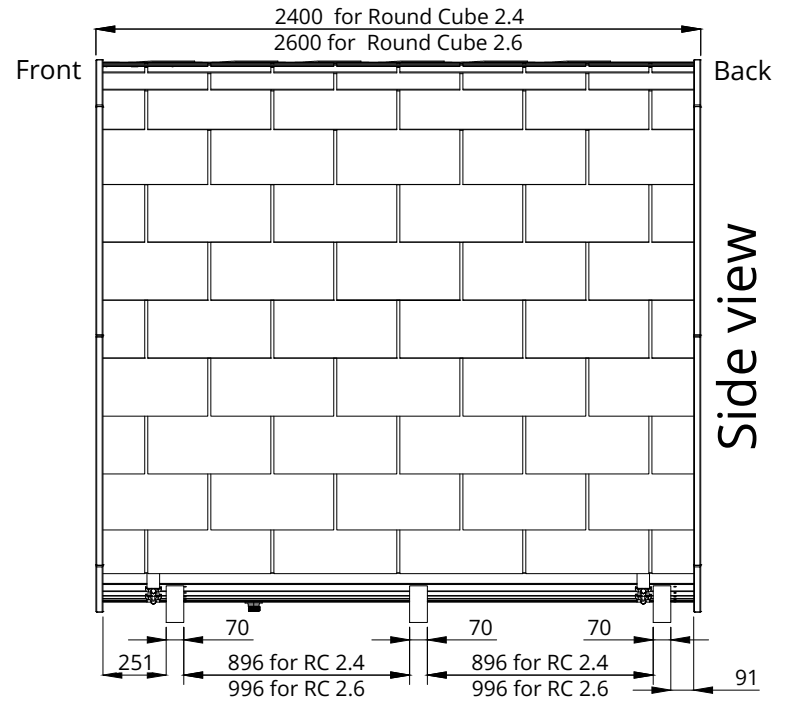

Side view

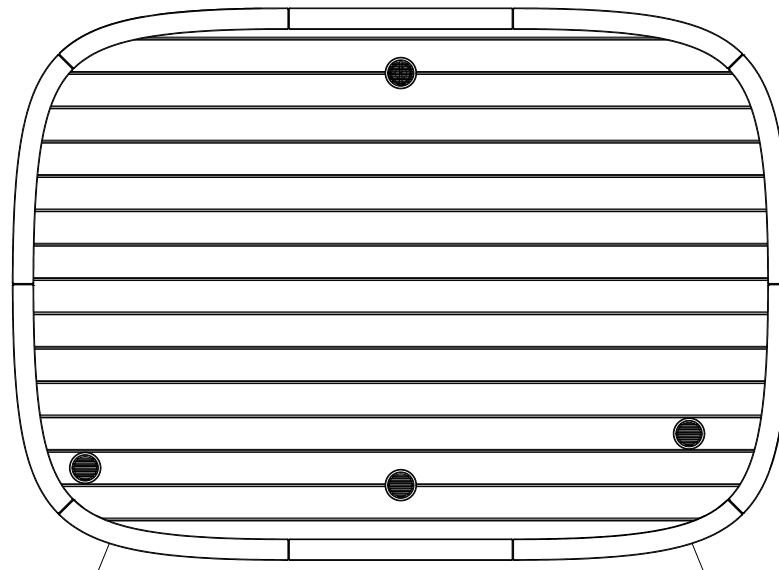

Back view

Scale 1 : 30

Round Cube

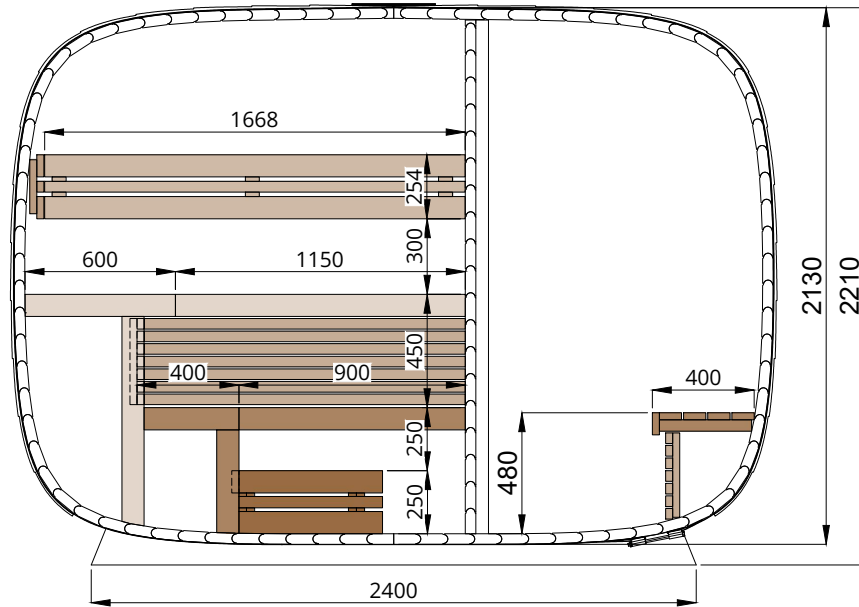
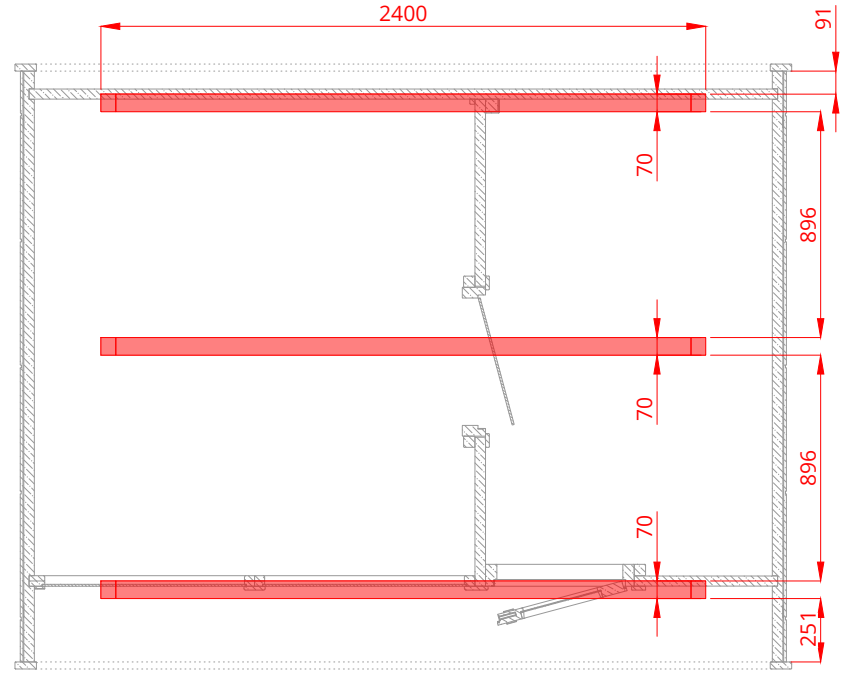
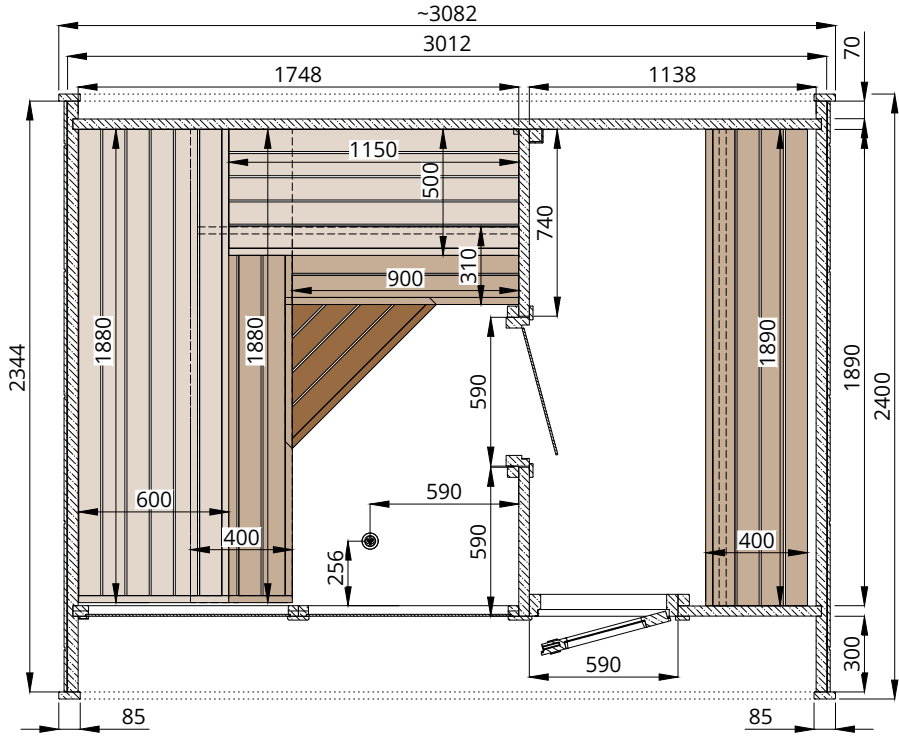

Scale 1 : 30

Round Cube 2.4

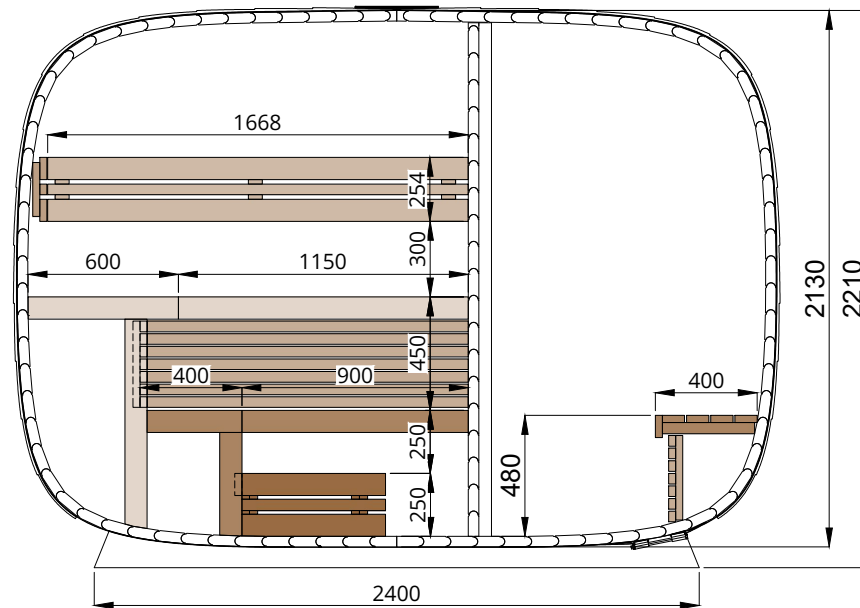
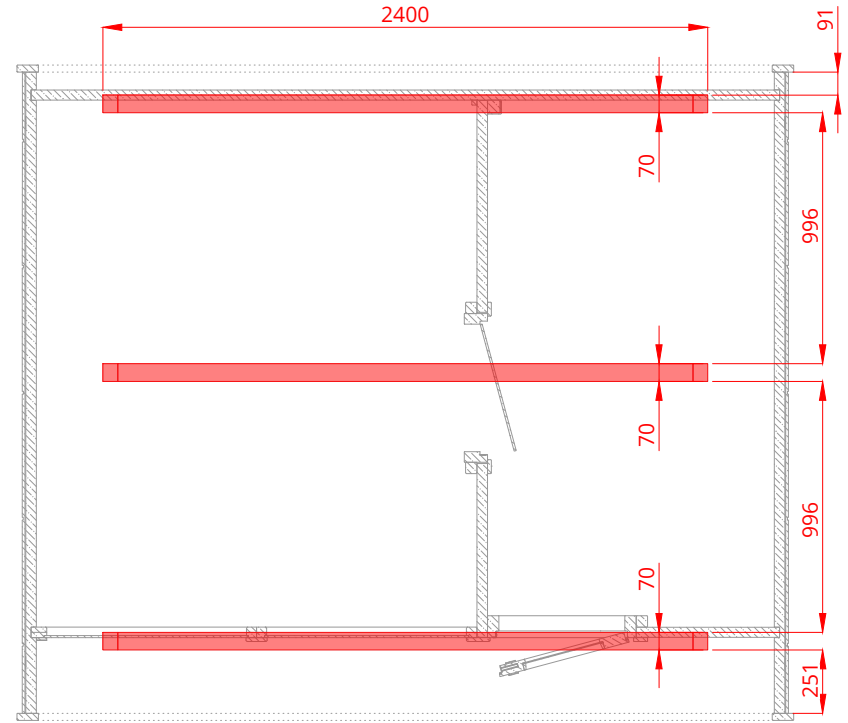
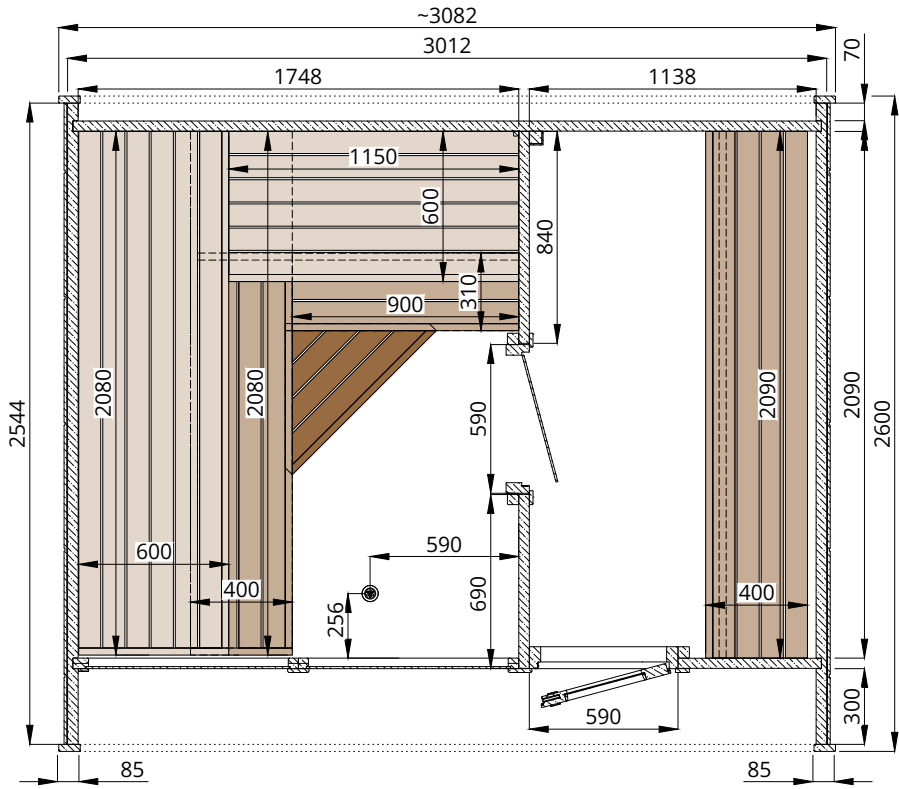

Scale 1 : 30

Round Cube 2.6

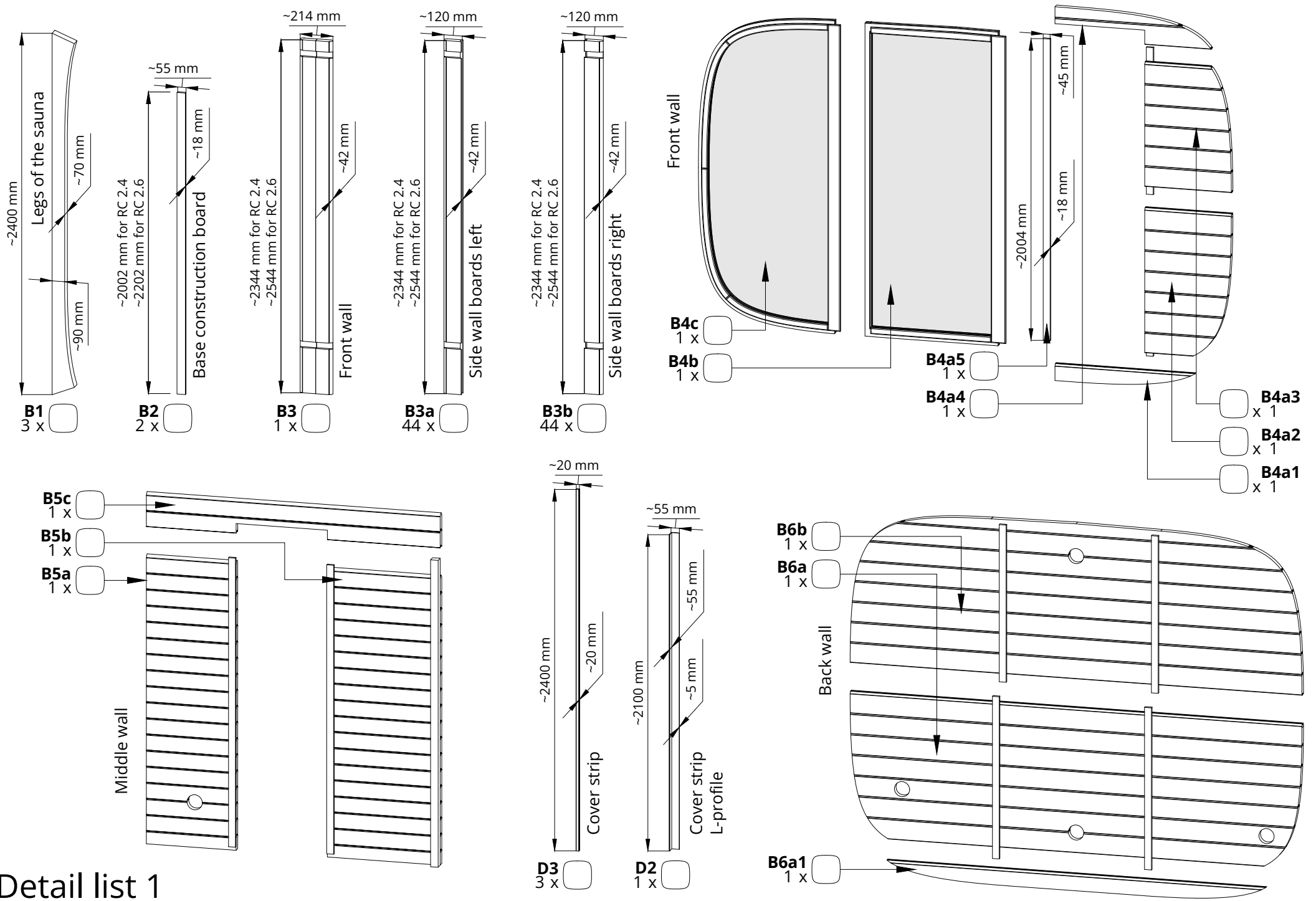

Detail list 1

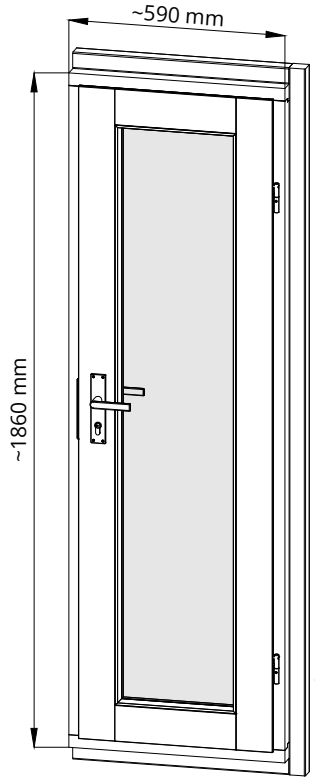
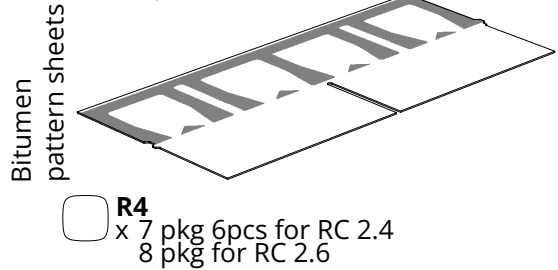
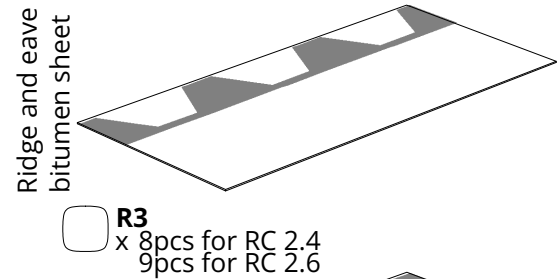
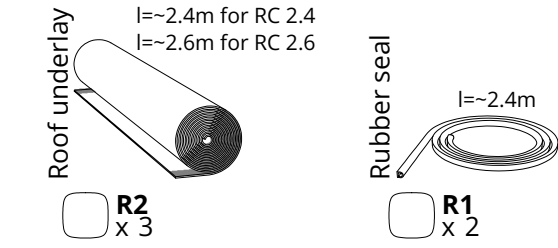

B7.1
1 x

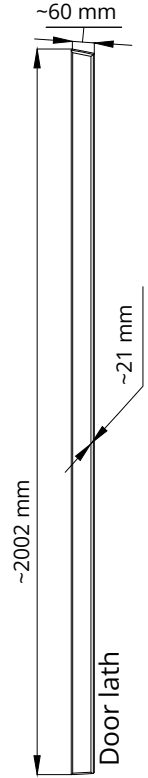

B7.1a
1 x

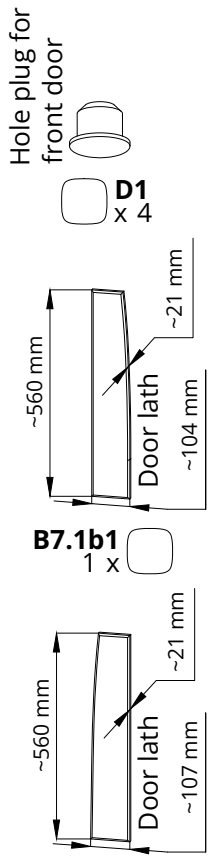

B7.1b2
1 x

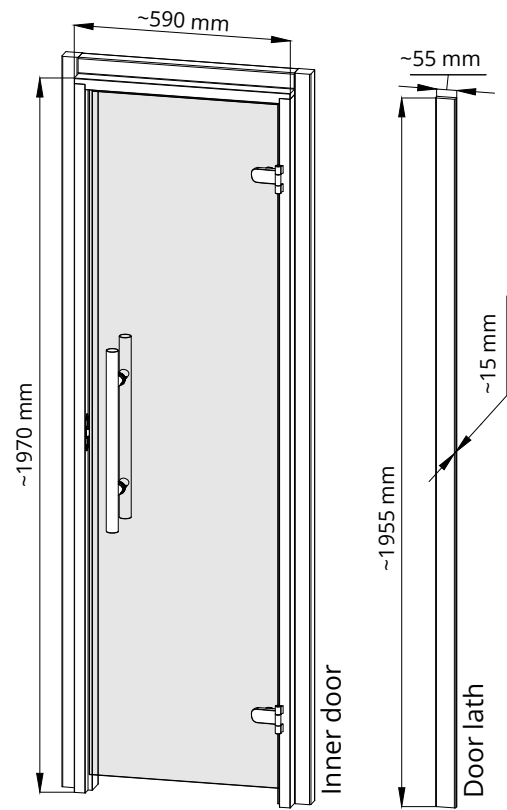

B7.2
1 x

B7.2a
2 x

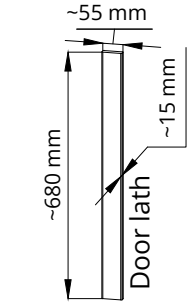



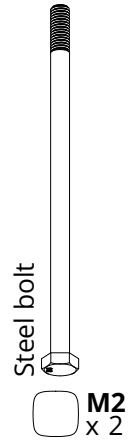
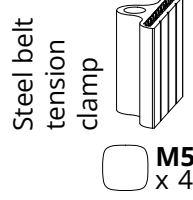
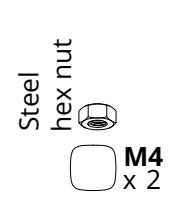
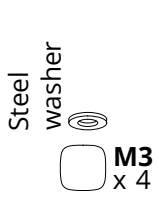
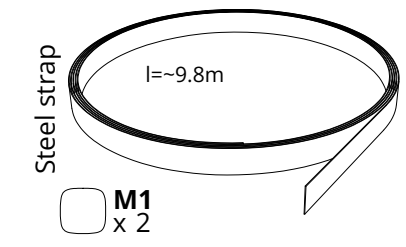
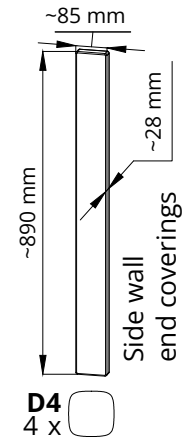
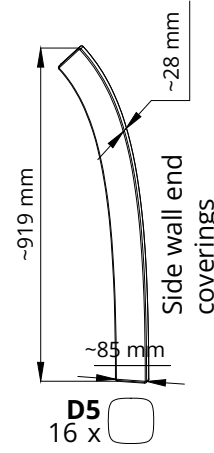
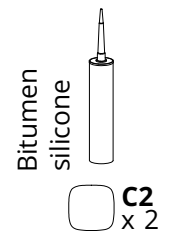
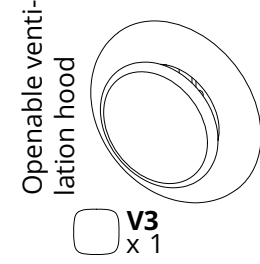
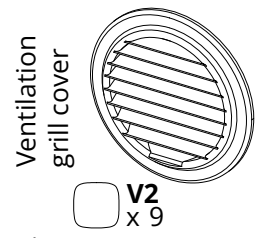
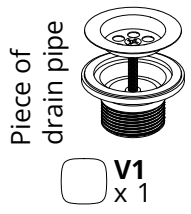



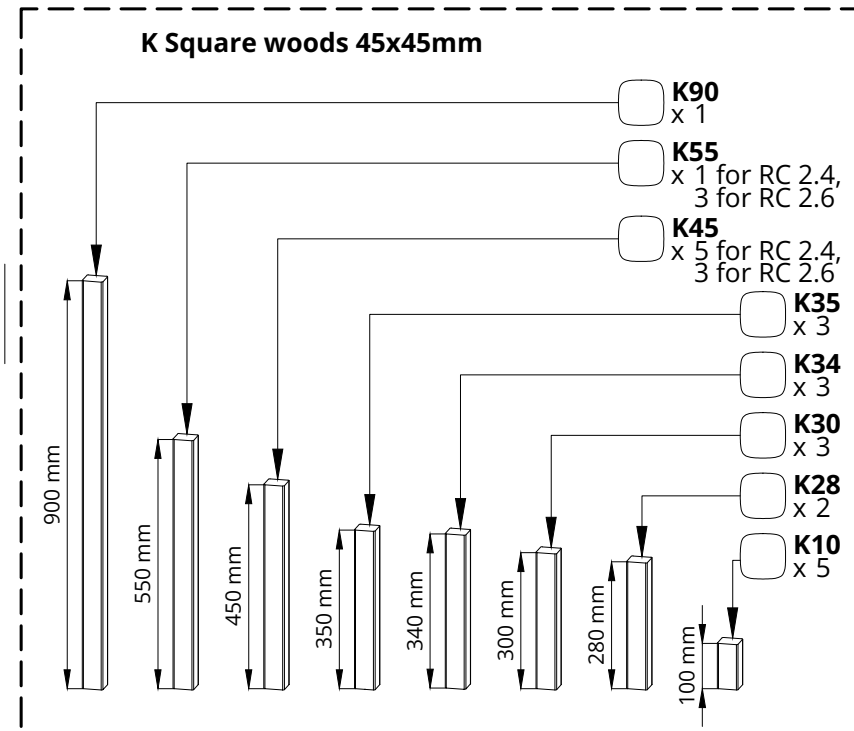
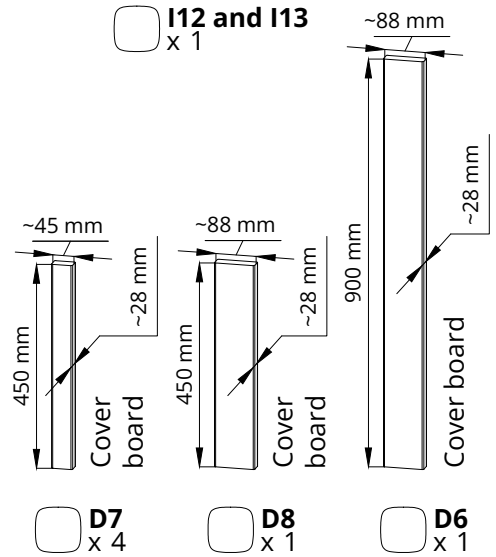
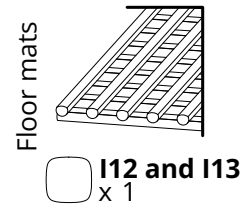
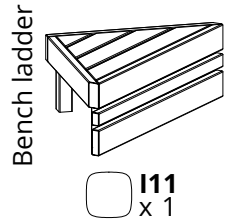
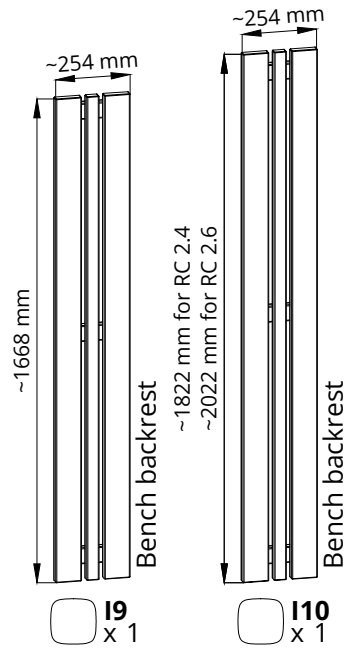
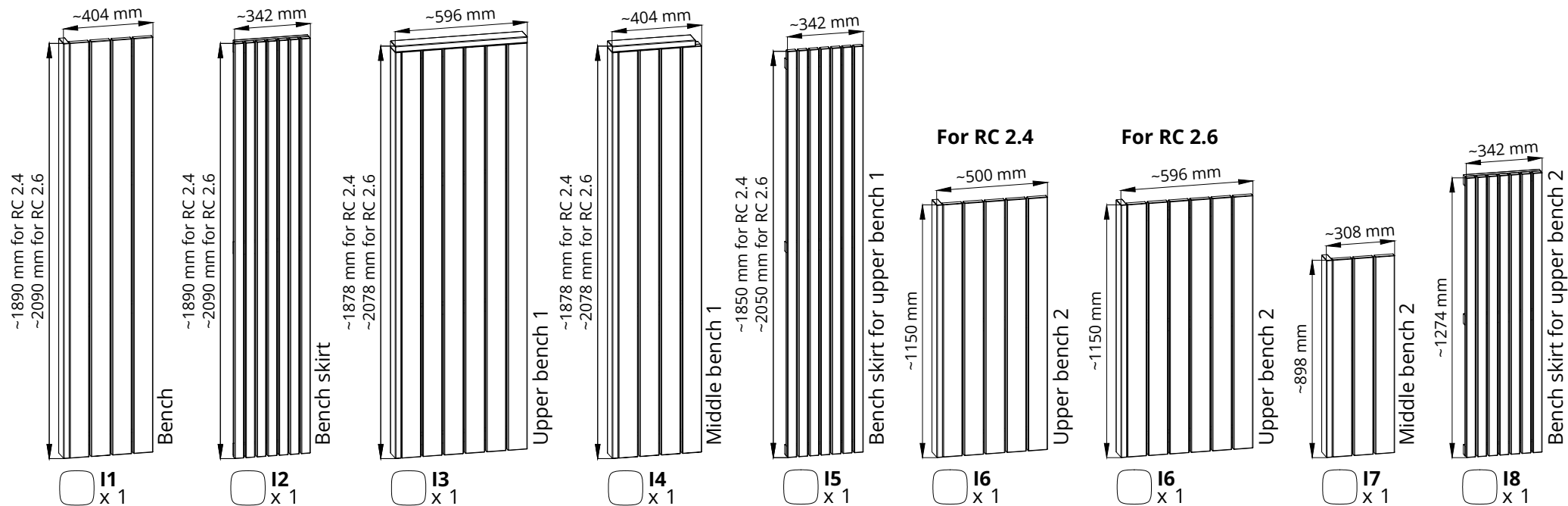

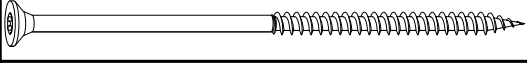
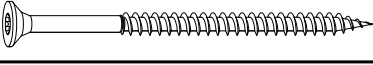

B7.2b
1 x



Detail list 2

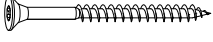

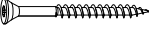
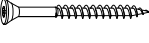
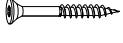
Detail list 3

Nails and screws (Scale 1:2)	Area of use	Name in in. manual	Screw size	Quantity	
	To fasten the walls	S9	Screws 6x140	x8	<input type="checkbox"/>
	Not in use in this sauna Mainly for construction inside and outside	S8	Screws 6x100	x0	<input type="checkbox"/>
 	Mainly for construction inside and outside	S7	Screws 4,5x80 for Spruce Screws 4,2x75 for Thermo	x200	<input type="checkbox"/>
	For fixing the door(s)	S6.2	Screws 4,2x75	x45	<input type="checkbox"/>
	For fixing the side wall end coverings	S6.1	Screws 4,5x70 (black coated)	x60	<input type="checkbox"/>
 	Mainly for construction inside and outside	S5	Screws 4,5x60 for Spruce Screws 4,2x55 for Thermo	x200	<input type="checkbox"/>
	Not in use in this sauna Only for the window(s)	S4	Screws 4,2x55	x0	<input type="checkbox"/>
	Not in use in this sauna Only for the window frame(s)	S3	Screws 3x40	x0	<input type="checkbox"/>
	Mainly for construction inside and outside	S2	Screws 3x40	x40	<input type="checkbox"/>
	Mainly for construction inside and outside	S1	Screws 3x30	x54	<input type="checkbox"/>
	During roof installation	R5	Nail 2,5x20	1kg	<input type="checkbox"/>

Detail list 4

S7	Screws 4,5x80 for Spruce Screws 4,2x75 for Thermo	x12
		

NB! use a level

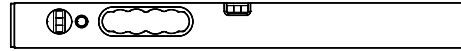

The base of the sauna must be level!

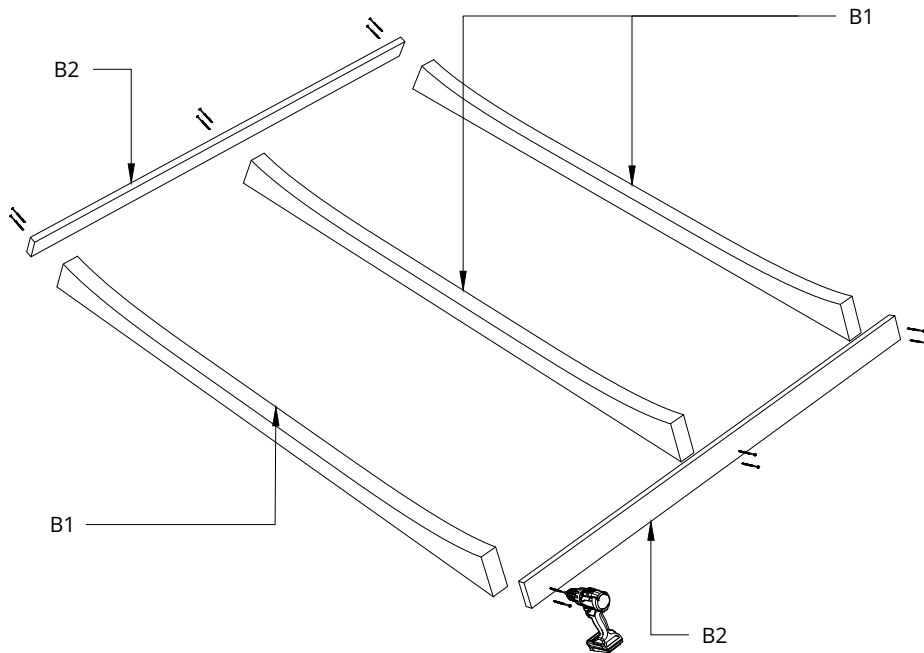
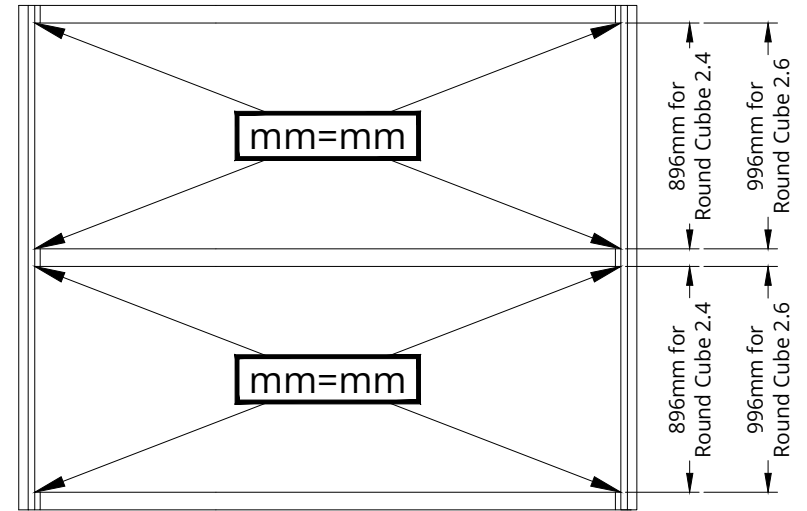

S7	Screws 4,5x80 for Spruce Screws 4,2x75 for Thermo	x6
		

Use two screws for point A1, A2 and A3 (see sketch).

Please countersink the screw head!

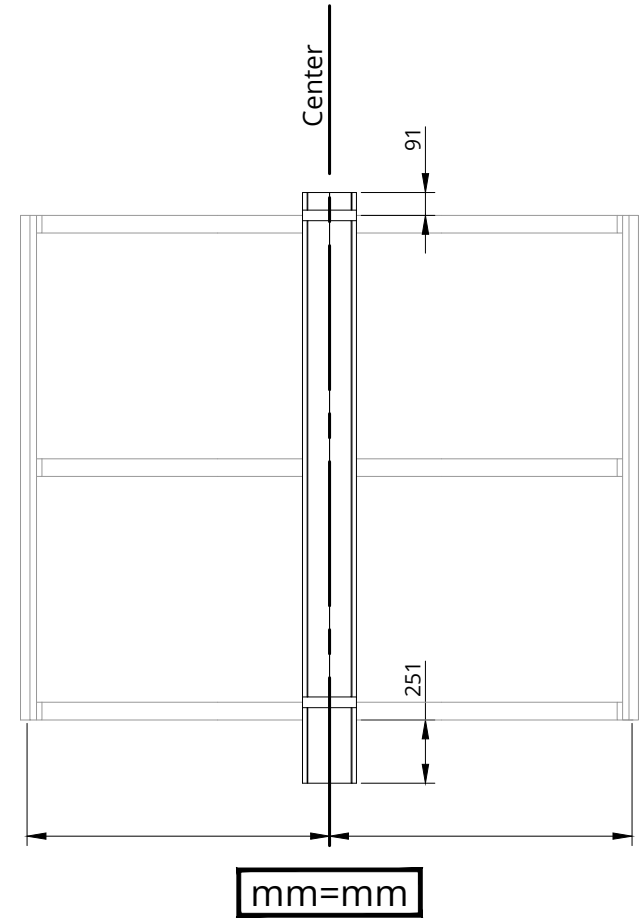
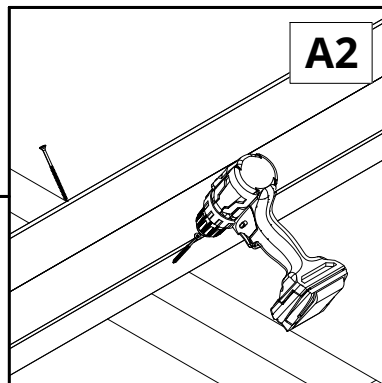
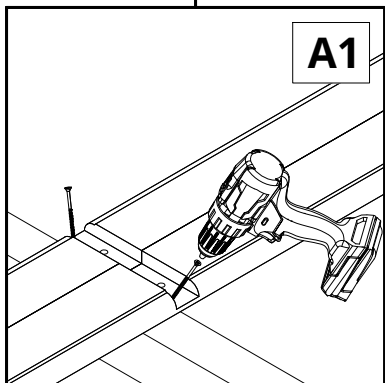
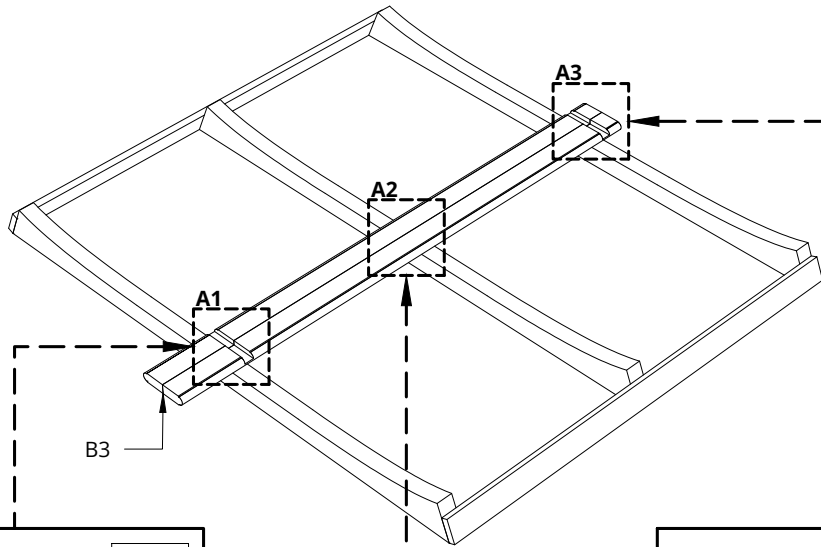
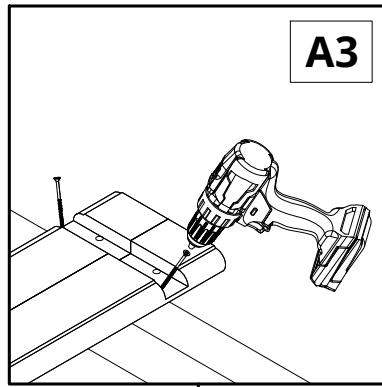

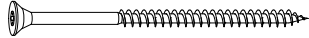
S7	Screws 4,5x80 for Spruce Screws 4,2x75 for Thermo	x60
		

Use a rubber mallet to tap the planks together.

Screw each plank B3a and B3b to the foundation B1 with a screw. ~10 pieces on each side left B3a and right B3b.

Please countersink the screw head!

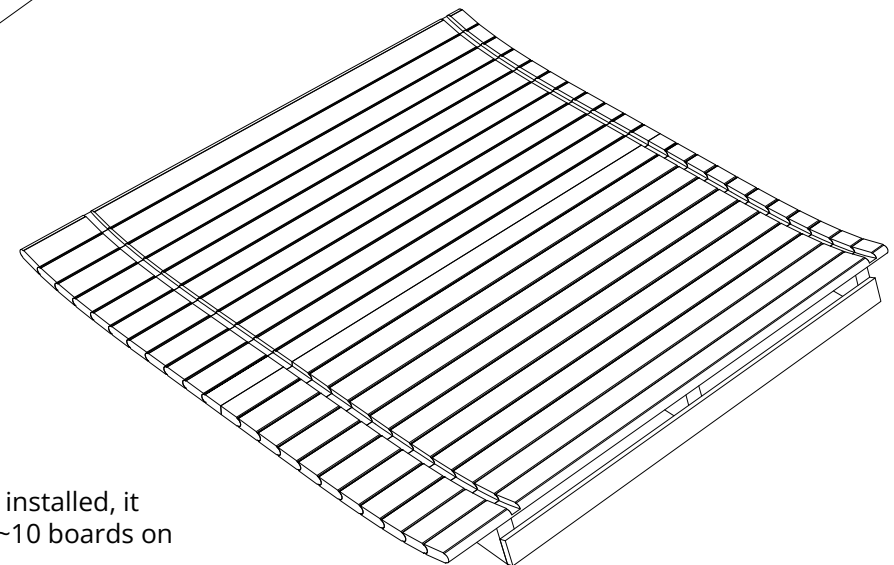
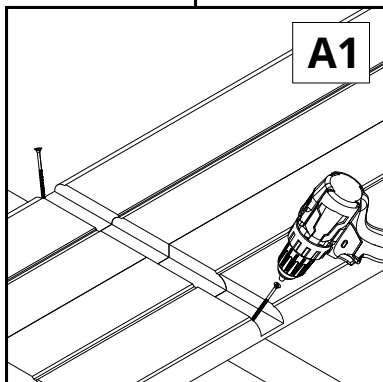
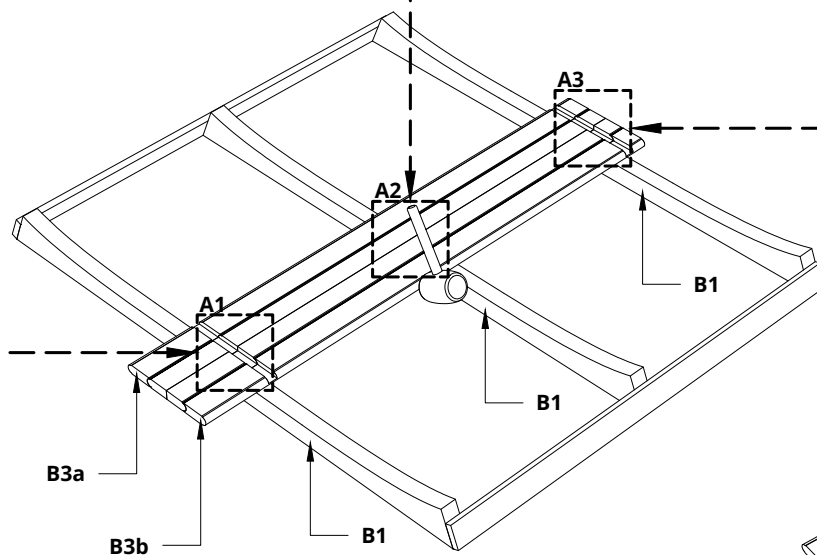
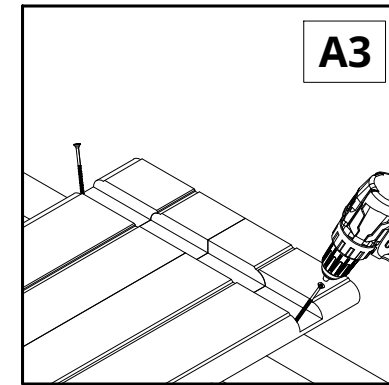
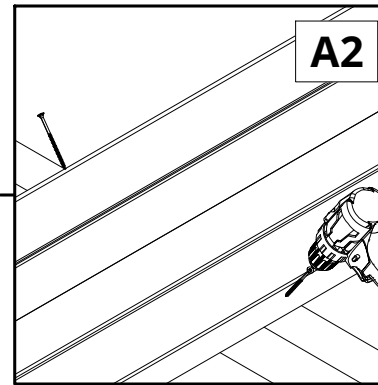

When the boards are installed, it should look like this. ~10 boards on each side.

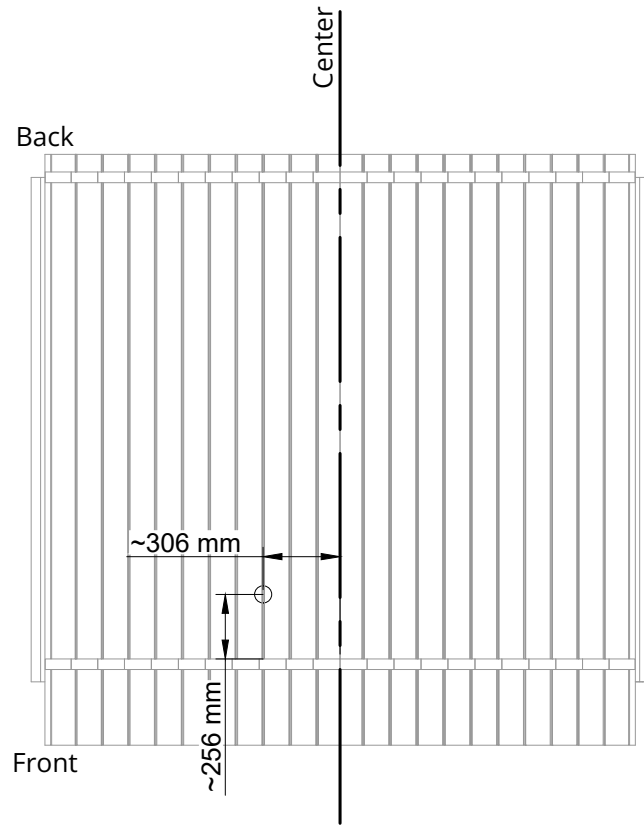

Before installation of the drain pipe, hole must be cut with a hole saw.

Install a piece of drain pipe V1.

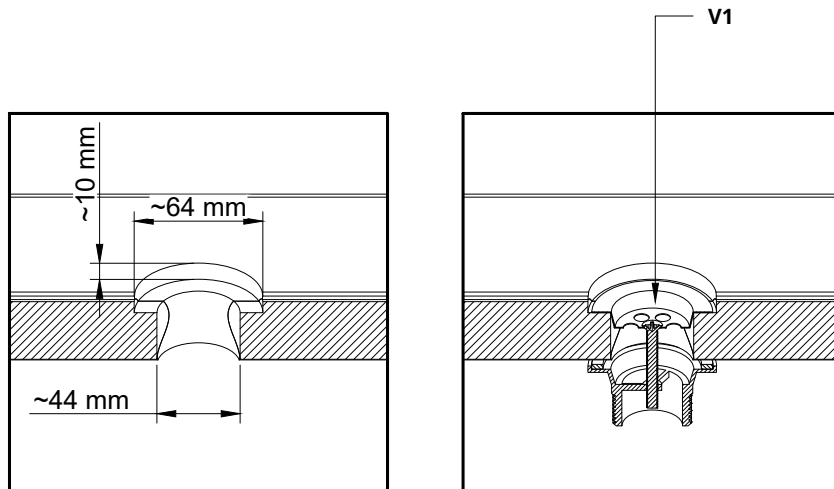
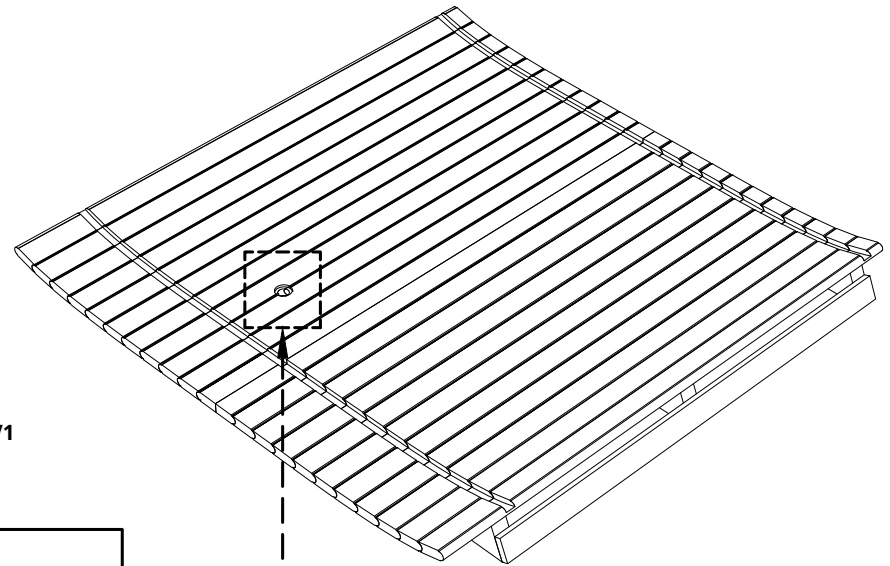

Lay R1 (rubber seal) to the inside of the groove as shown in picture A1 and A2.

Drill 10 mm hole in each plank, in the front wall groove and in the back wall groove to the outside as shown in the picture A3 and A4.

Remove the connecting beam B2 on both sides.

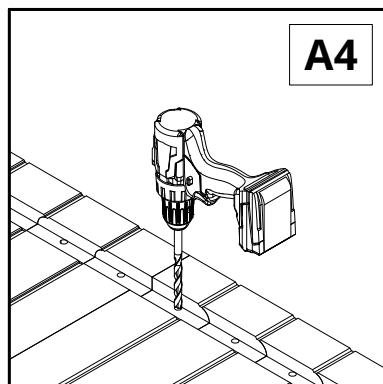
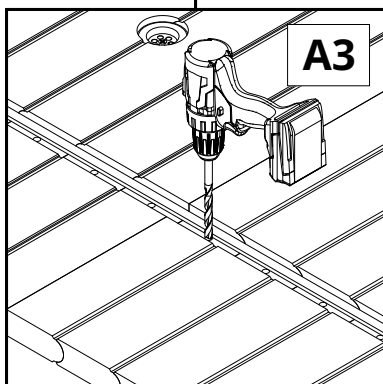
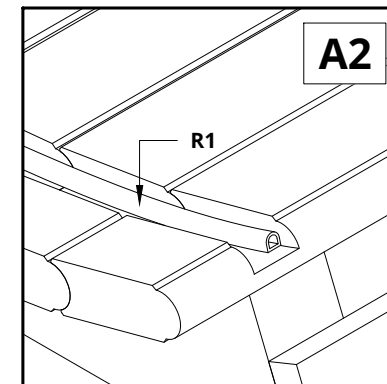
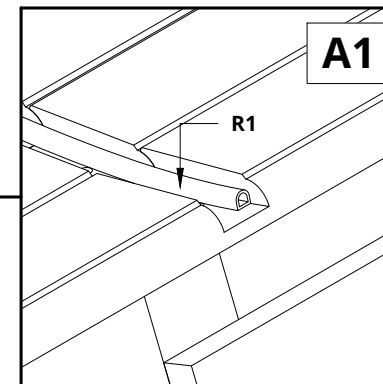
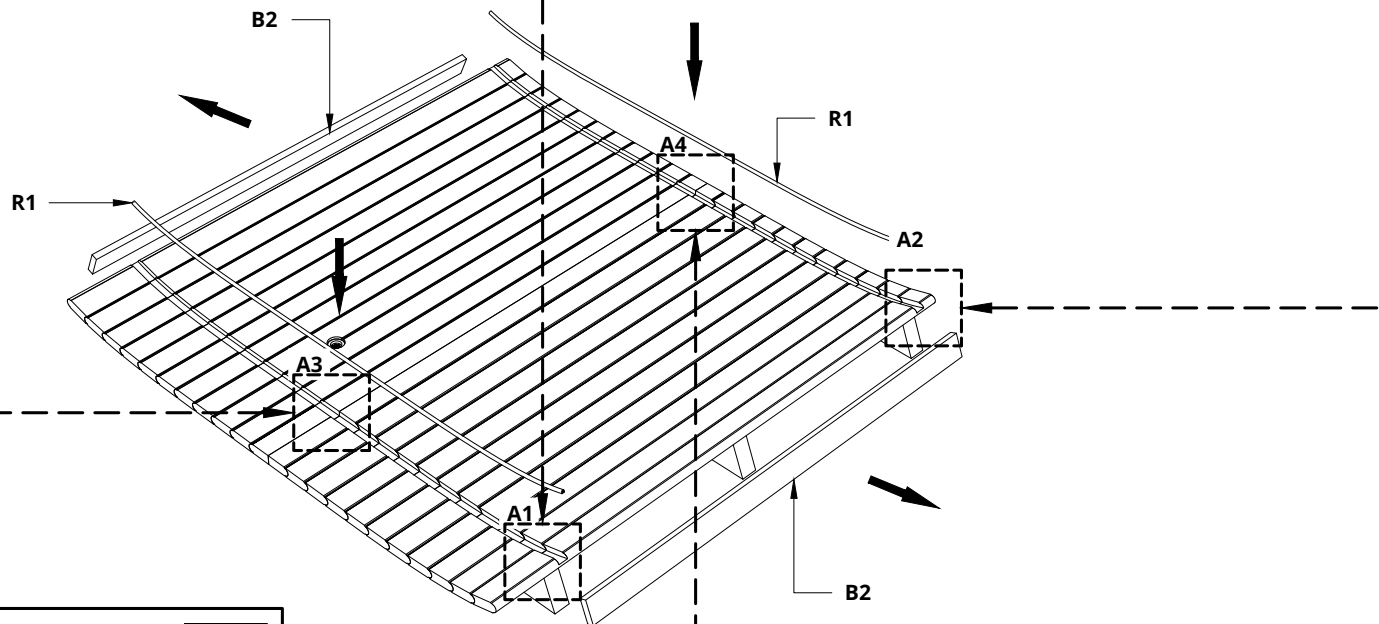

S7	Screws 4,5x80 for Spruce Screws 4,2x75 for Thermo	x2
S5	Screws 4,5x60 for Spruce Screws 4,2x55 for Thermo	x2
		

Preparation of the lower part of the back wall and the middle wall for installation.

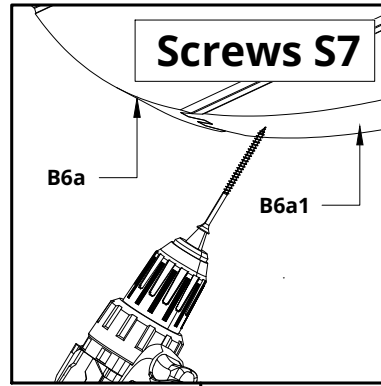

Preparing the middle wall consists of removing pieces of the wall from the wall sections.

B5a and B5b, remove the first board piece from the bottom and label these pieces accordingly.

From B5c, separate second board and label the piece accordingly.

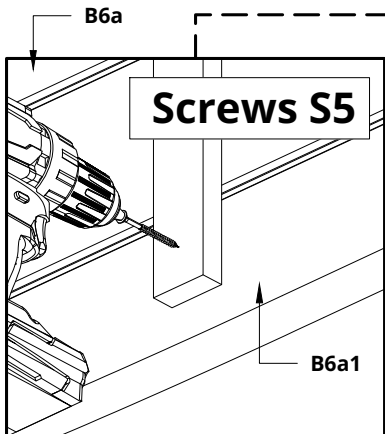
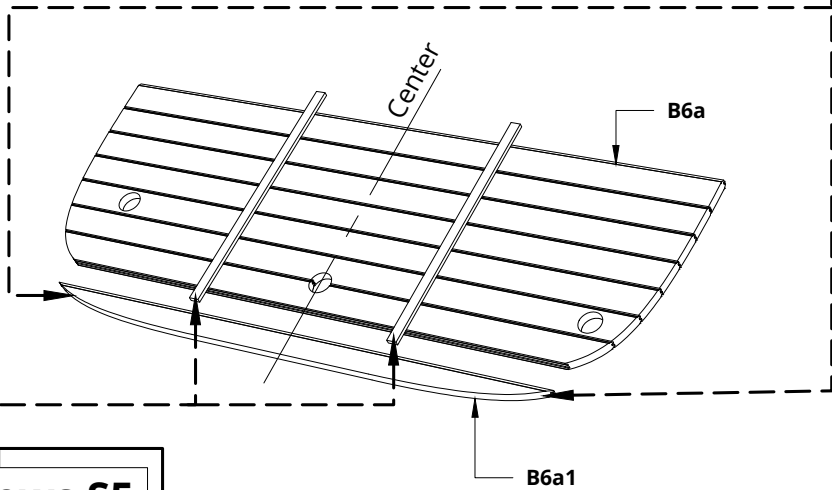

When assembling the lower part of the back wall, mark the centers of both parts and make sure that the centers are aligned.

Please countersink the S7 screw head!

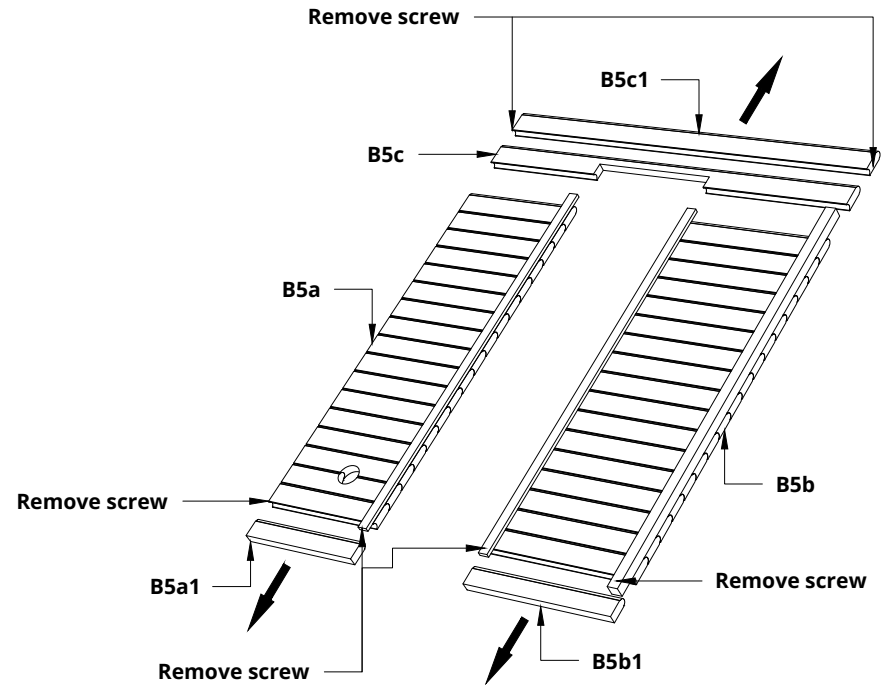

S7	Screws 4,5x80 for Spruce Screws 4,2x75 for Thermo	x3
S5	Screws 4,5x60 for Spruce Screws 4,2x55 for Thermo	x5
		

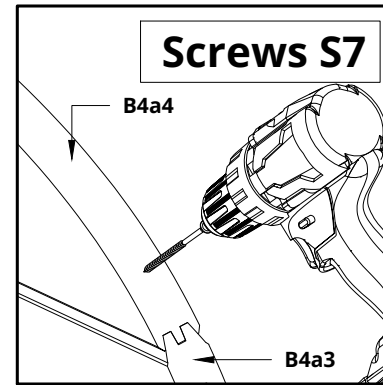
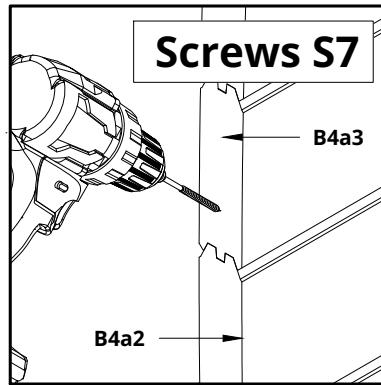

Preparation of the wooden part of the front wall.

By assembling the wooden part of the front wall, make sure that the door opening is correct.

Please countersink the S7 screw head!

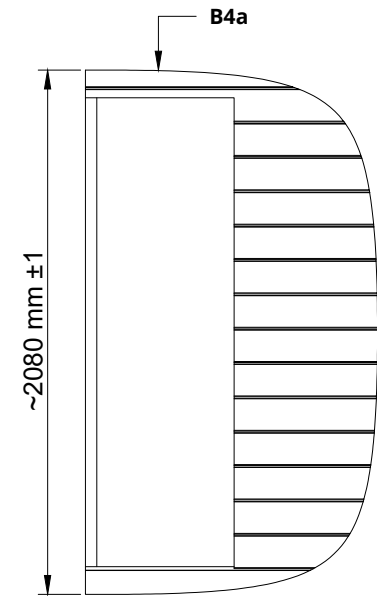
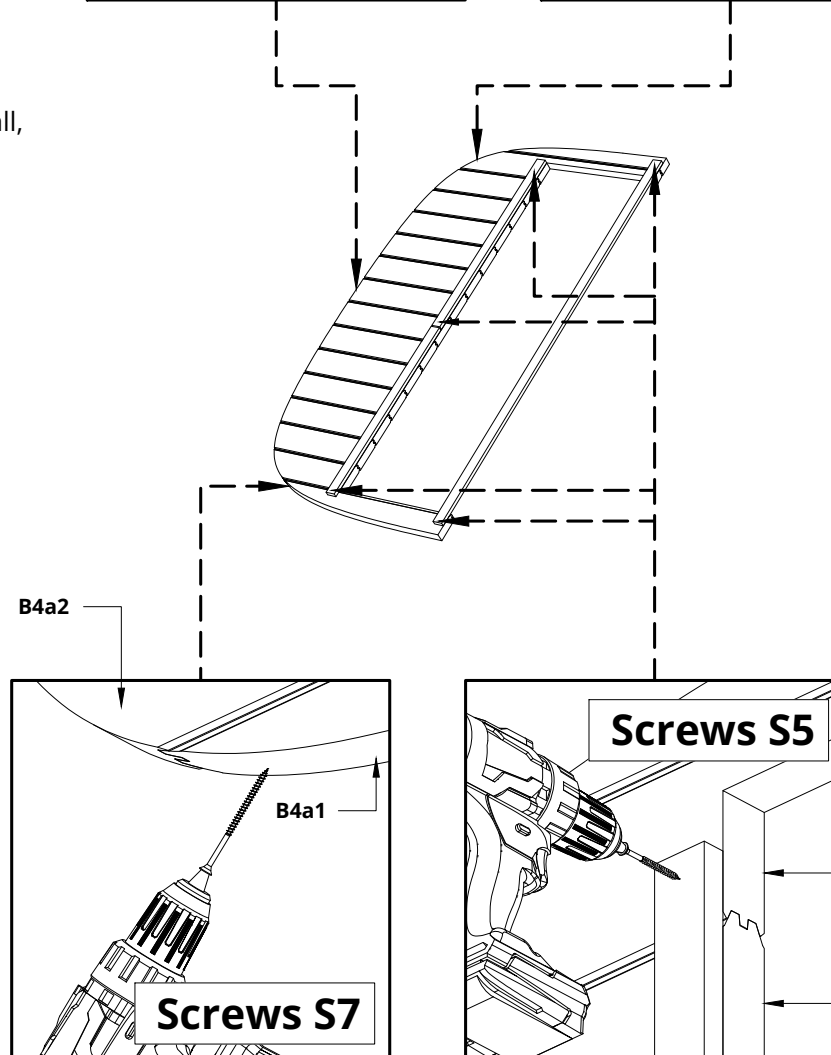
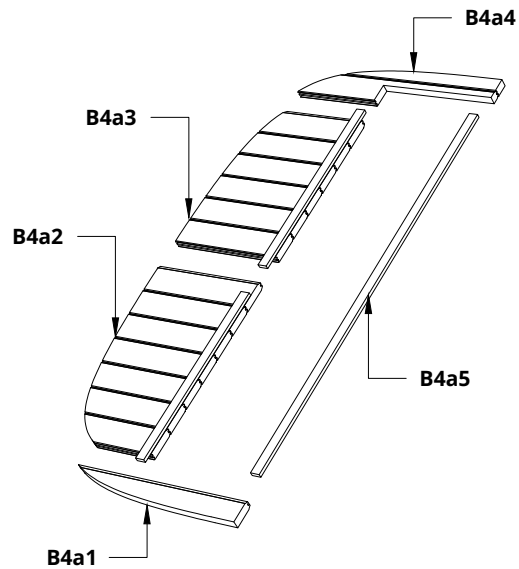

S5	Screws 4,5x60 for Spruce Screws 4,2x55 for Thermo	x2
		

NB! use a level

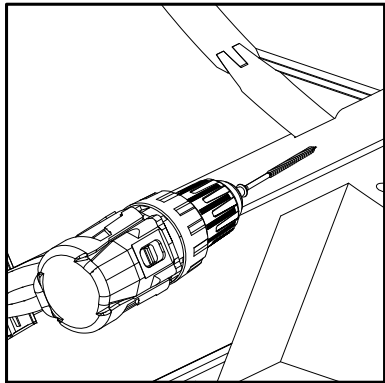

B6a

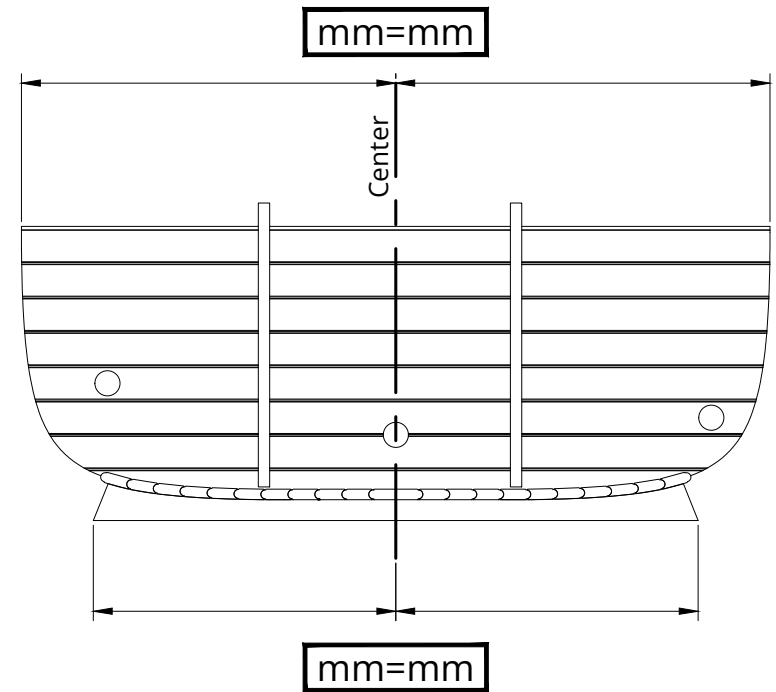
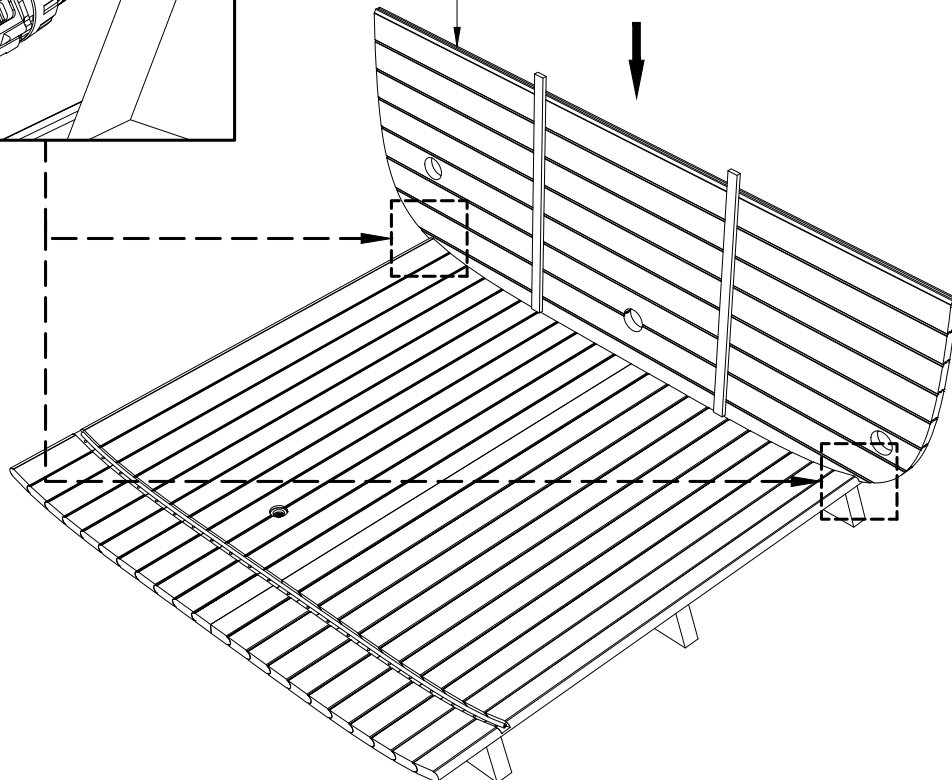

First install the lower part of the back wall. The lower part of the back wall must be in the center of the base.

If the lower part of the back wall is in place, then it must be fixed with screws. The screw locations are shown in the picture.

Please countersink the screw head!

S9	Screws 6x140	x4
		

Install the B5a1 and B5b1 of the middle wall, which were removed earlier from B5a and B5b. They must be installed 284 mm away from the center as shown in the pictures.

If they are correctly in place, fasten them both (B5a1 and B5b1) with two screws, shown in the picture.

When you start fixing B5a1 and B5b1 drill small holes for screws (Recommended).

Please countersink the screw head!

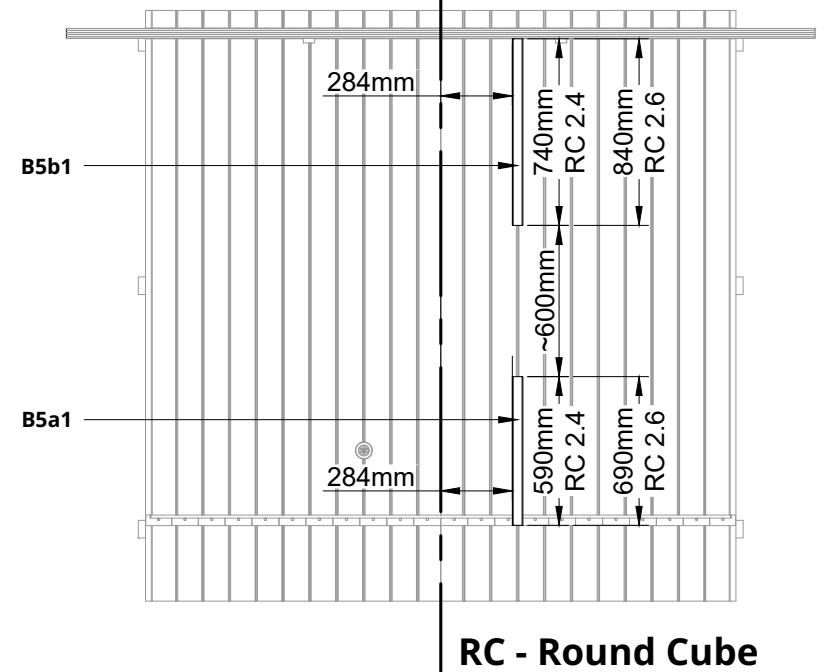
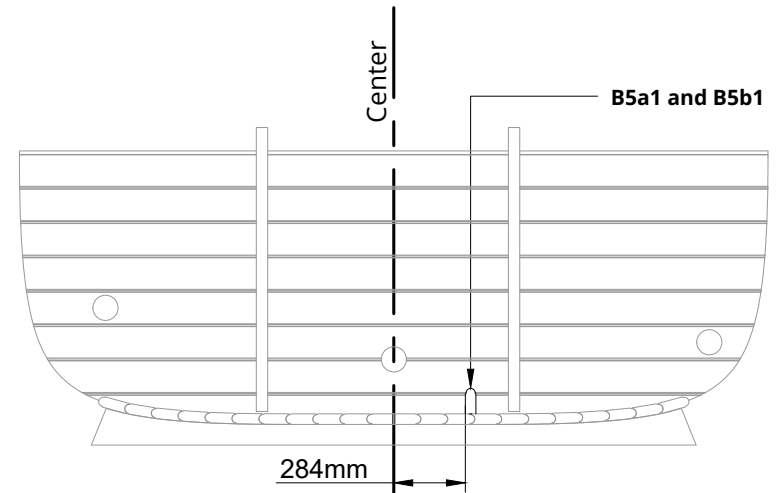
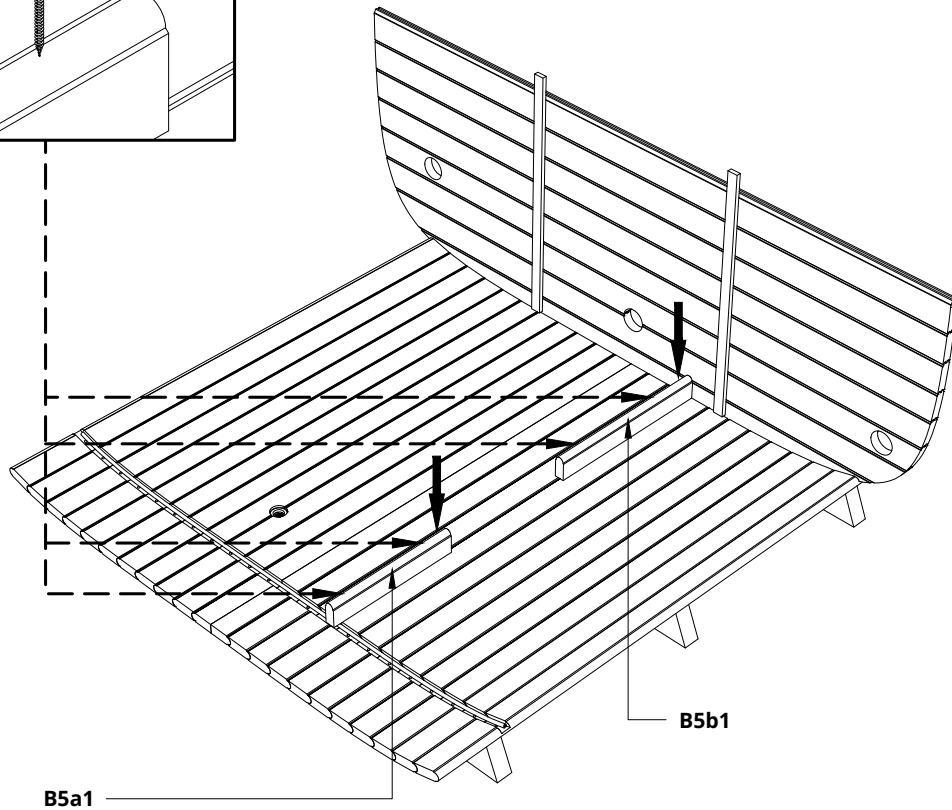
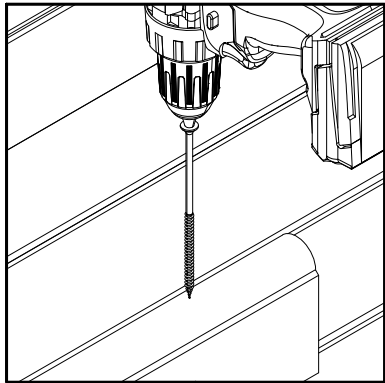

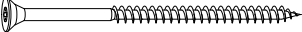
S9	Screws 6x140	x2
S7	Screws 4,5x80 for Spruce Screws 4,2x75 for Thermo	x10
S5	Screws 4,5x60 for Spruce Screws 4,2x55 for Thermo	x4
		

NB! use a level

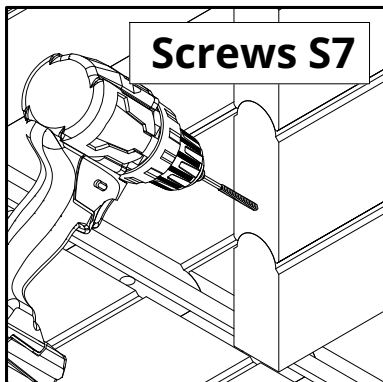
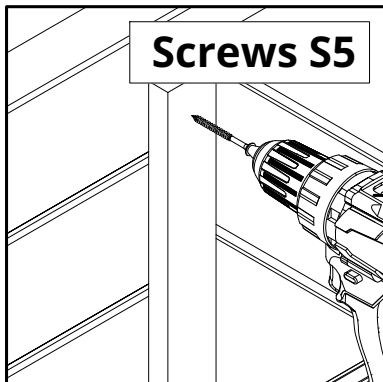
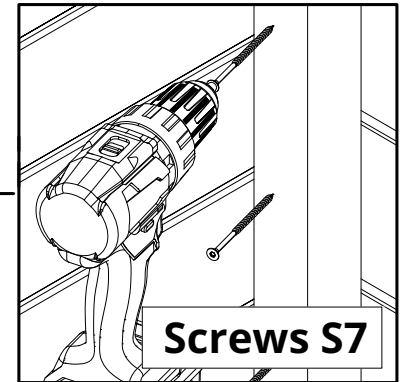
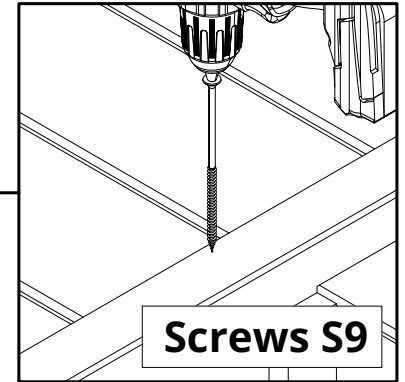
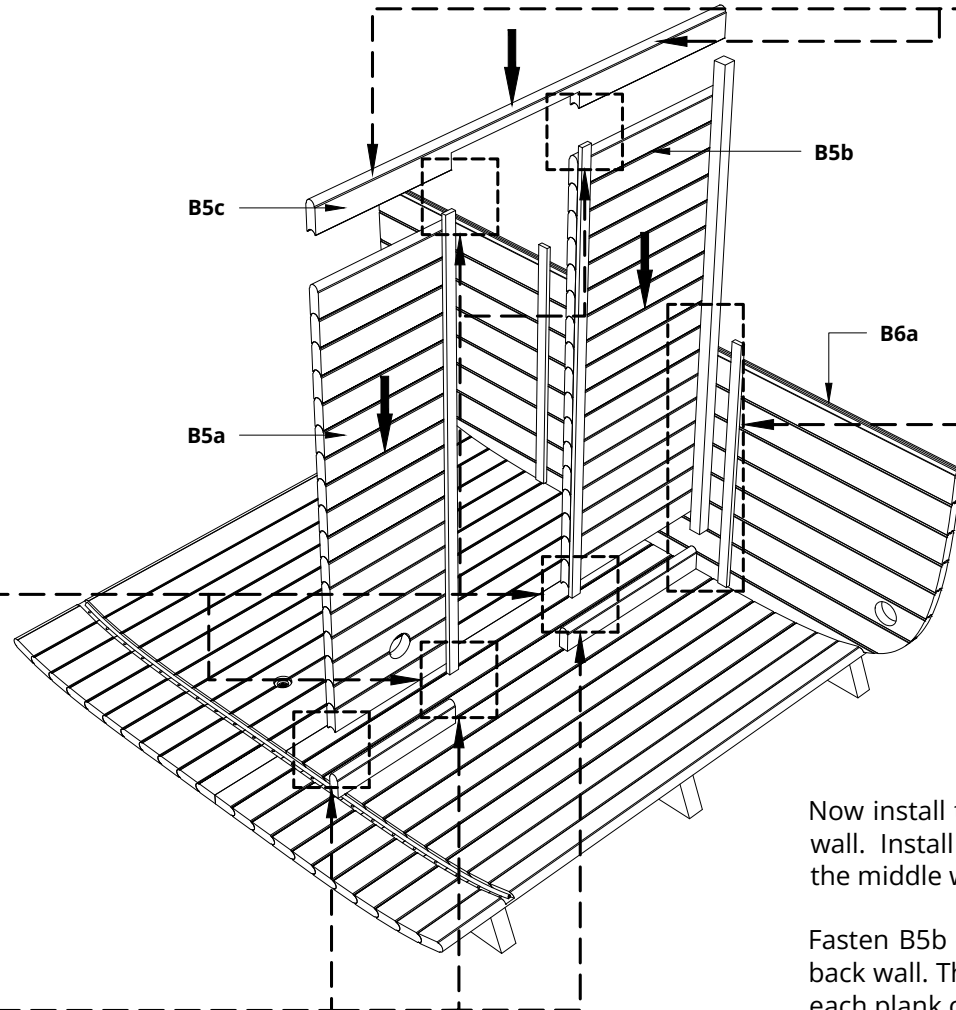

Now install the parts B5a and B5b of the middle wall. Install B5b first and then the other parts of the middle wall.

Fasten B5b with screws to the lower part of the back wall. Then the screws must be screwed into each plank of the back wall.

When you start fixing B5c drill small holes for screws (Recommended).

Please countersink the S7 and S9 screw head!

S7	Screws 4,5x80 for Spruce Screws 4,2x75 for Thermo	x10
		

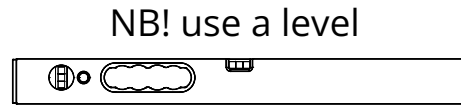

Now install the upper parts of the back wall B6b. If the upper part of the back wall is in place, fasten it to the lower part of the back wall with screws.

The upper part of the back wall must be attached to the middle wall in the same way as was done with the lower part of the back wall. Planks of the upper part of the back wall must all be screwed to the middle wall B5b.

If the back wall is fixed with screws, you can remove back wall connection bars.

Please countersink the screw head!

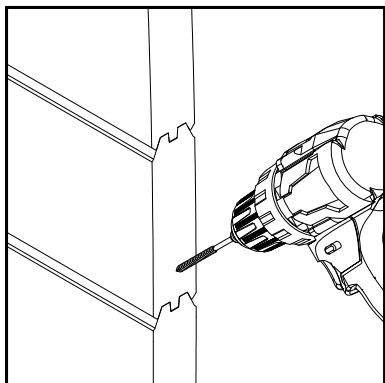
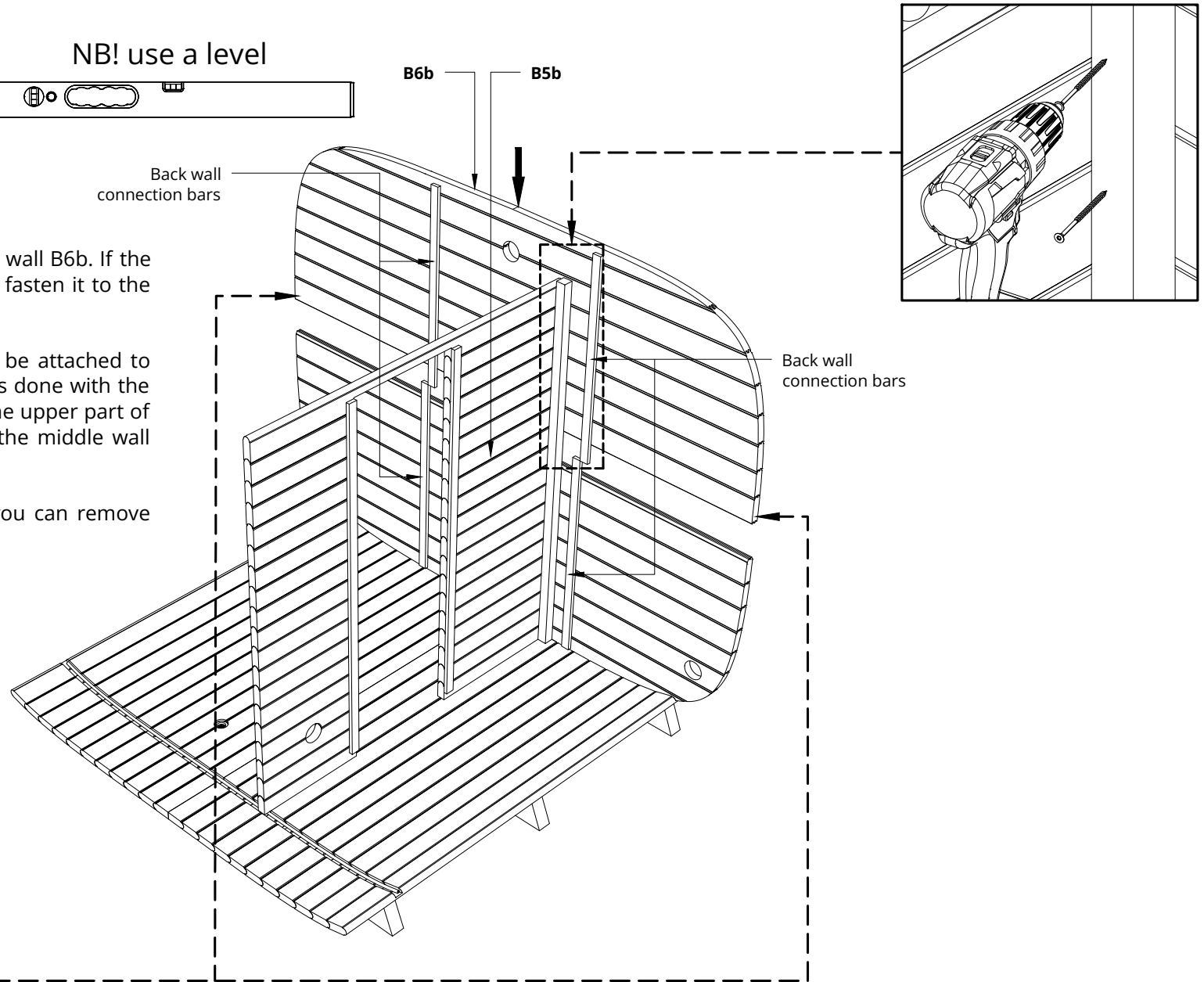

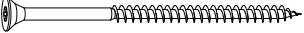
S7	Screws 4,5x80 for Spruce Screws 4,2x75 for Thermo	x20
S5	Screws 4,5x60 for Spruce Screws 4,2x55 for Thermo	x5
		

NB! use a level

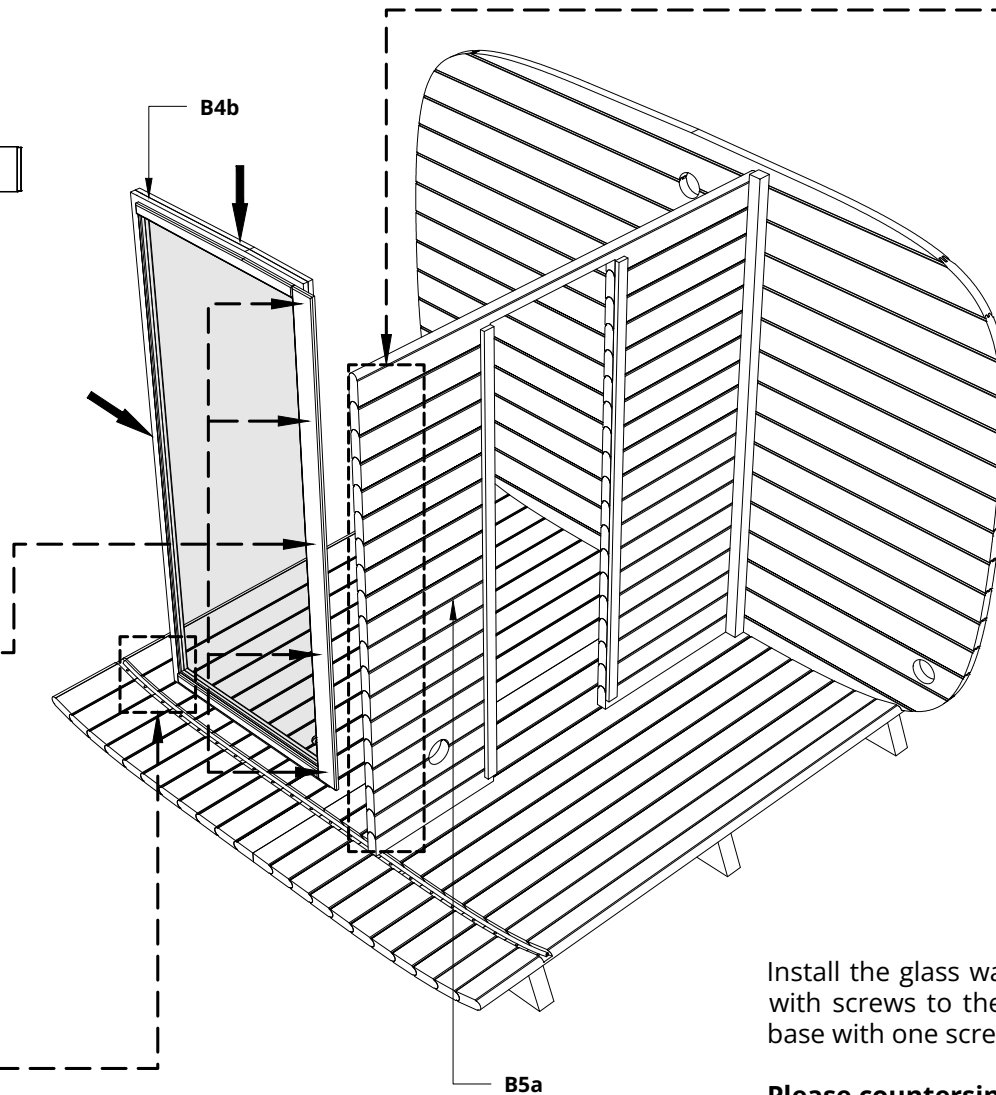
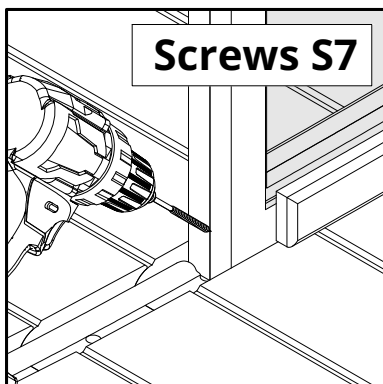
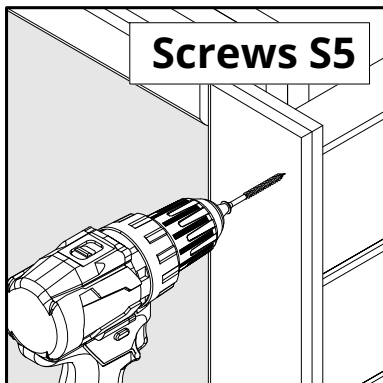
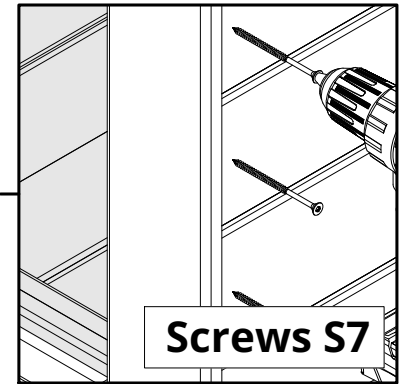
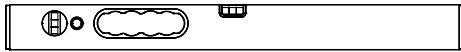

Install the glass wall part of the front wall B4b, and fix with screws to the B5a middle wall planks and to the base with one screw.

Please countersink the screw head!

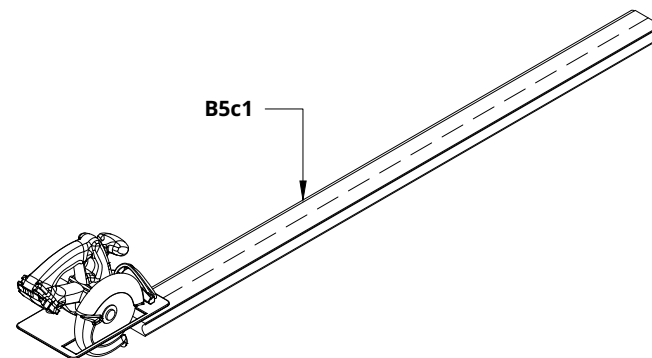
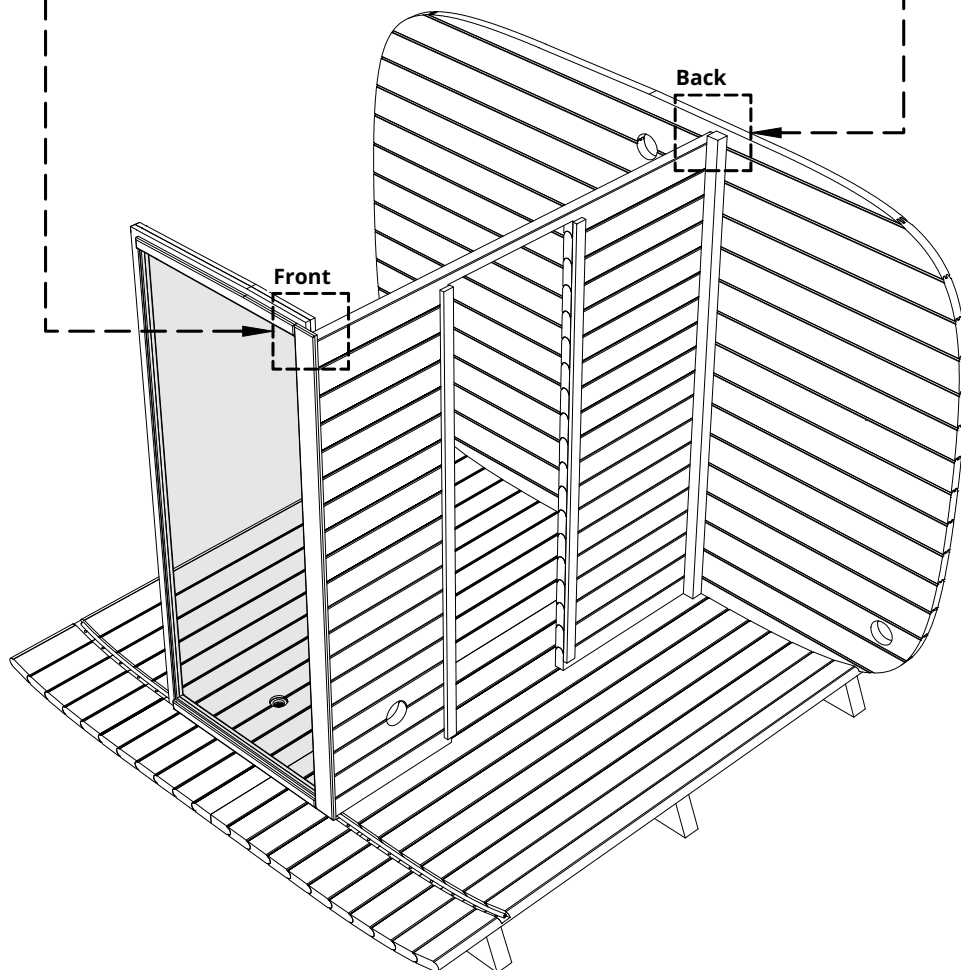
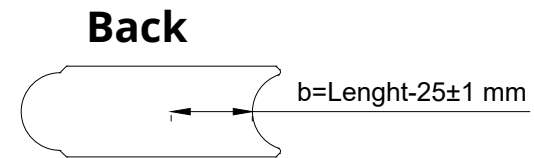
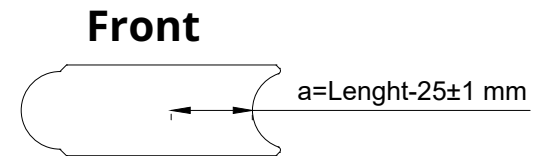
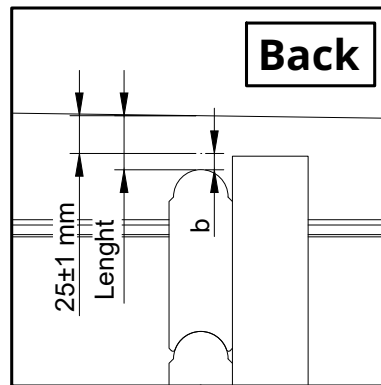
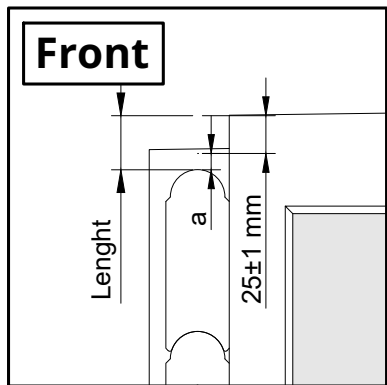

Attention! If the gap is 25mm, the following steps do not need to be performed and B5c1 does not need to be installed either.

Preparation of the last piece of the middle wall B5c1.

First, measure the height from the highest point of the middle wall to the upper edge of the back wall, then subtract 25mm from this measurement and you will get the measurement b. With the measurement in hand, mark the measurement on the board as shown.

Repeat these steps on the front wall side as well.

If both ends are marked, then they must be connected with a line, and then cut.

Please countersink the screw head!

S5	Screws 4,5x60 for Spruce Screws 4,2x55 for Thermo	x6
S2	Screws 3x40	x5
		

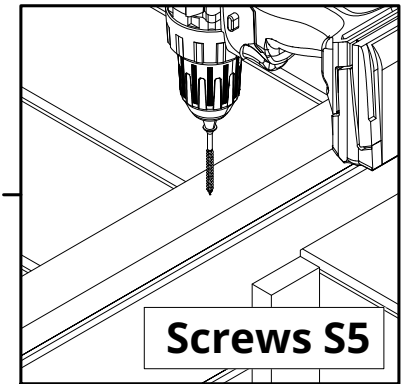
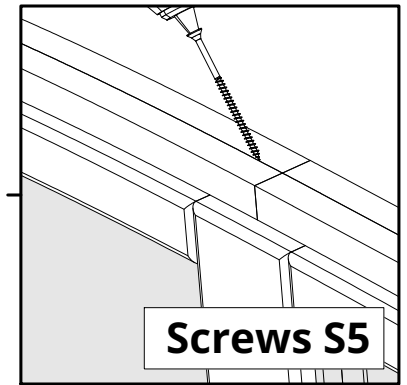
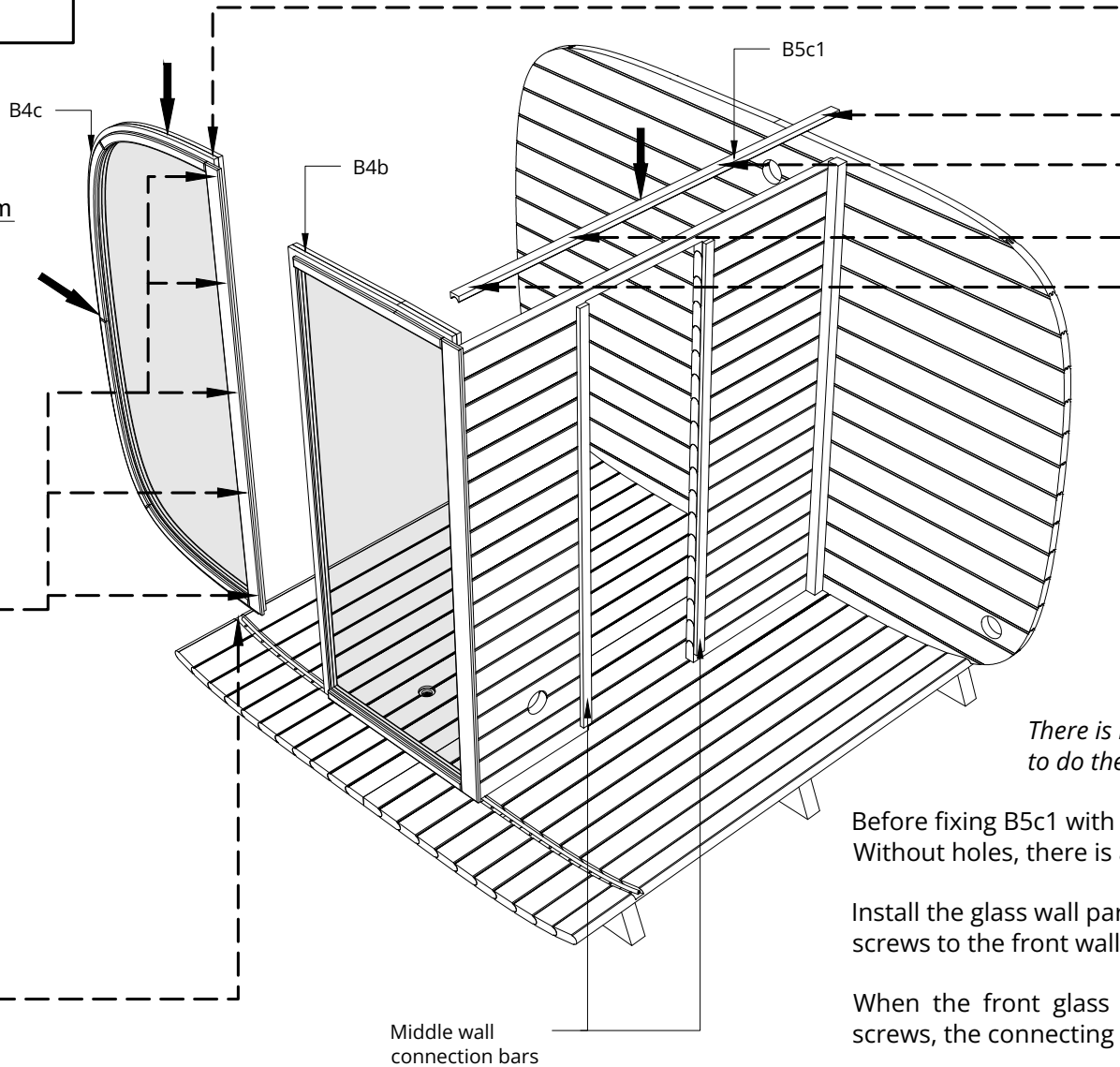
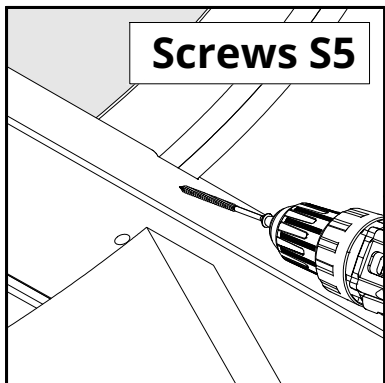
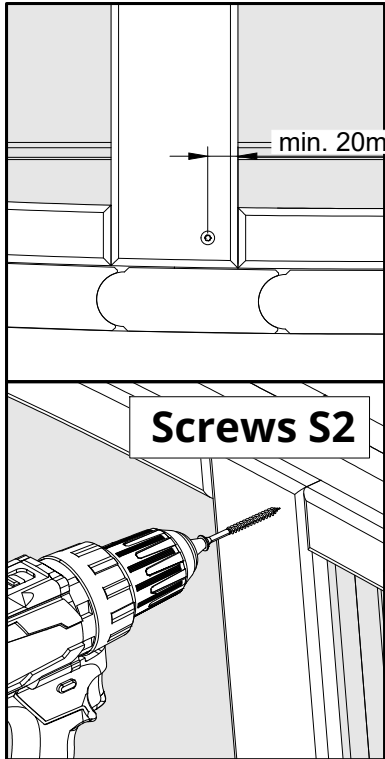

There is no need to install B5c1 if you didn't need to do the steps mentioned on the previous page.

Before fixing B5c1 with screws, pre-drill small holes for screws. Without holes, there is a greater risk that it may crack.

Install the glass wall part of the front wall B4c, and fix with screws to the front wall glass wall part B4b and to the base.

When the front glass wall part is assembled and fixed with screws, the connecting bars from middle wall can be removed.

Please countersink the screw head!

S7	Screws 4,5x80 for Spruce Screws 4,2x75 for Thermo	x6
S9	Screws 6x140	x1
		

NB! use a level

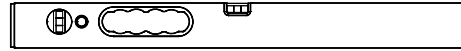

Before installing the wooden wall part of the front wall B4a, place one plank B3a or B3b between the glass part of the front wall and the back wall. It can be removed afterwards.

Install the wooden part of the front wall B4a. Before fixing with screws, install a piece of wood (cut it from the previously removed connecting bar) to the wooden wall part and the middle glass wall to hold the wooden wall part in place. It can be removed afterwards. Fix wooden wall part with screws to the base and to the middle wall.

Remove the connecting bars when you start installing the door!

Please countersink the screw head!

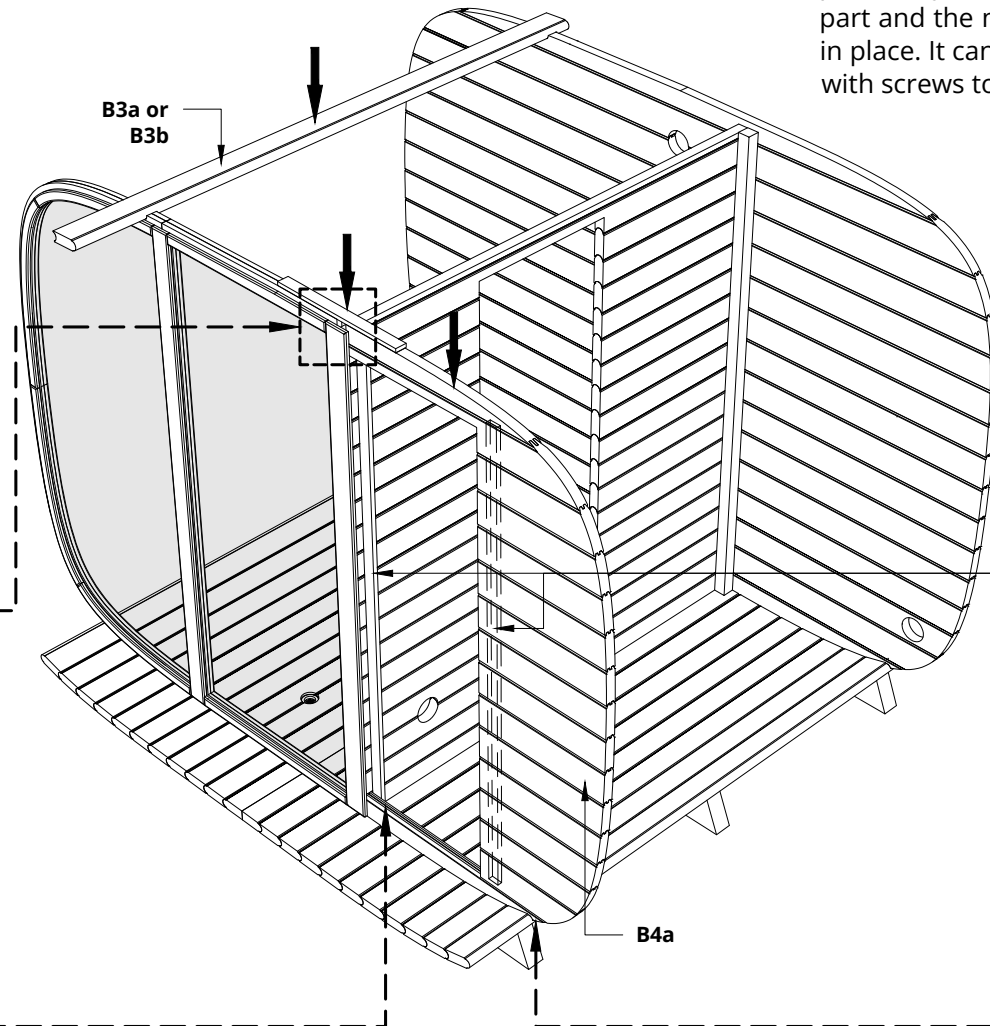
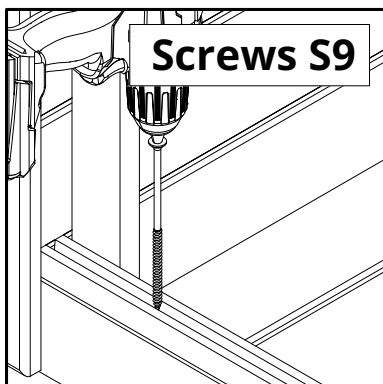
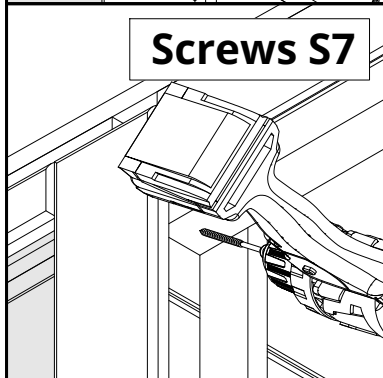
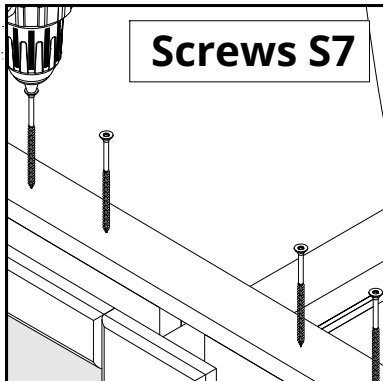

Connection bars

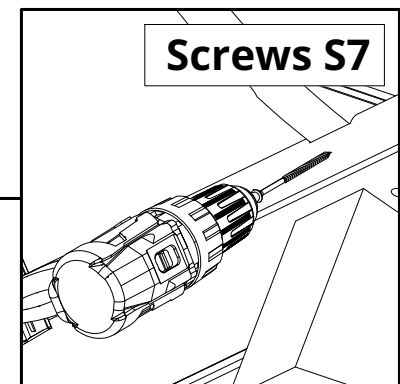

S5	Screws 4,5x60 for Spruce Screws 4,2x55 for Thermo	x120
		

Remove if it starts to interfere with the construction of the side wall.

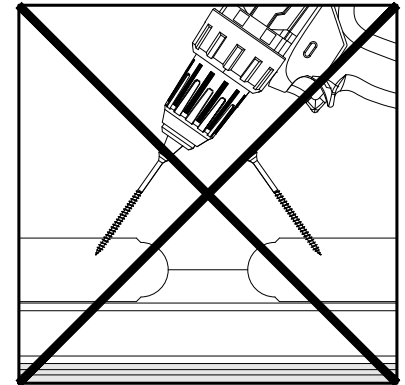
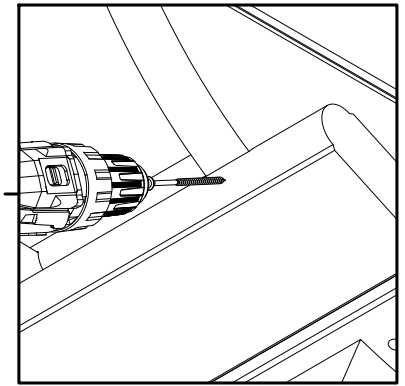
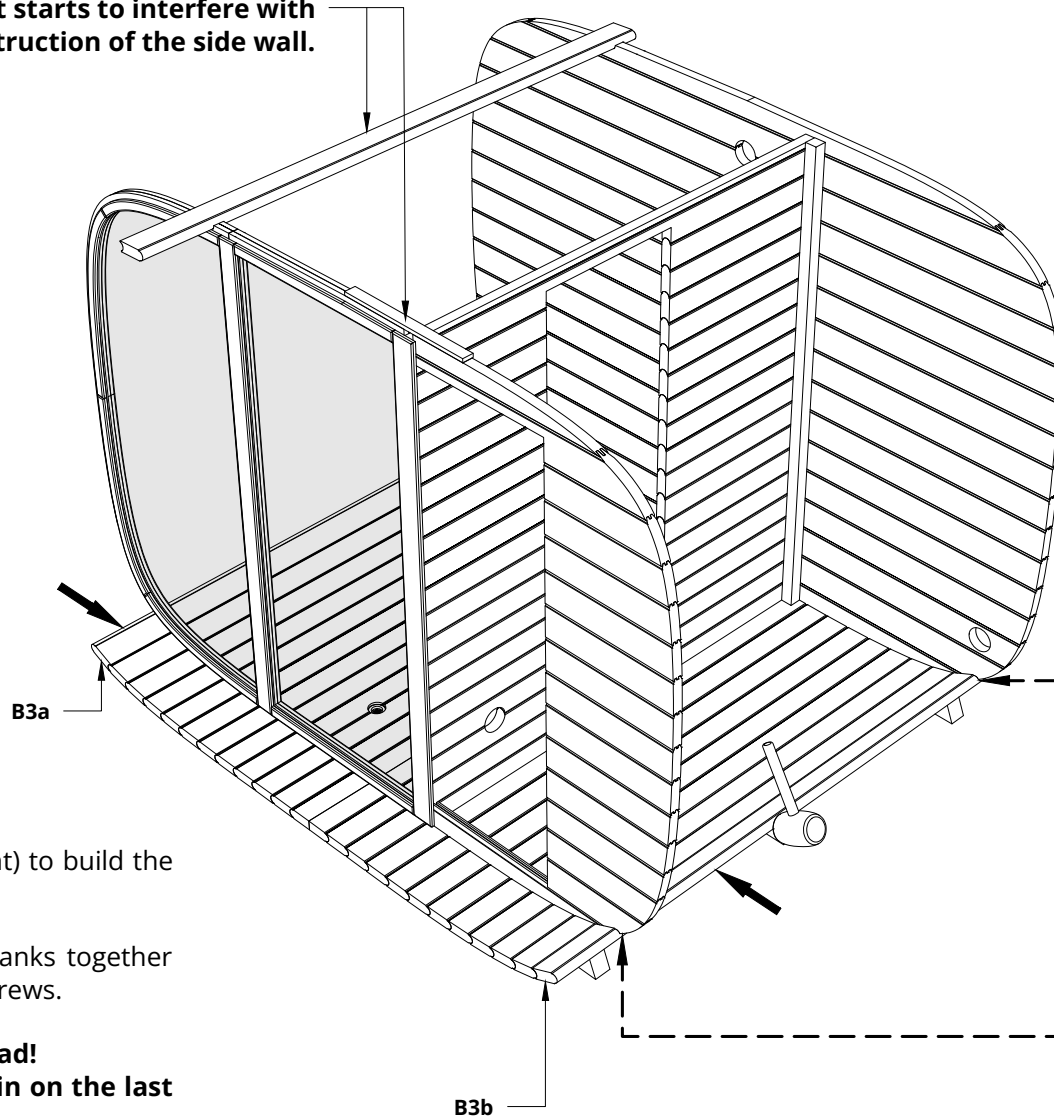

Use blanks B3a (left) and B3b (right) to build the side walls.

Use a rubber mallet to tap the planks together and then screw the plank with 2 screws.

Please countersink the screw head!
Please do not screw the screws in on the last whole blanks immediately.

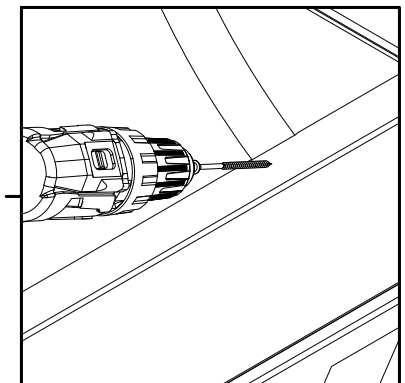

Please measure the gap front and back, the dimensions can be different.

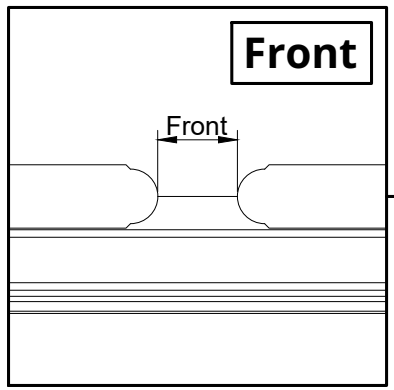
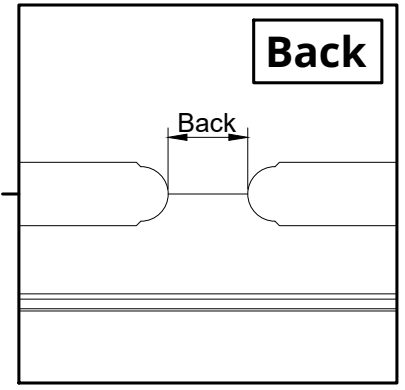
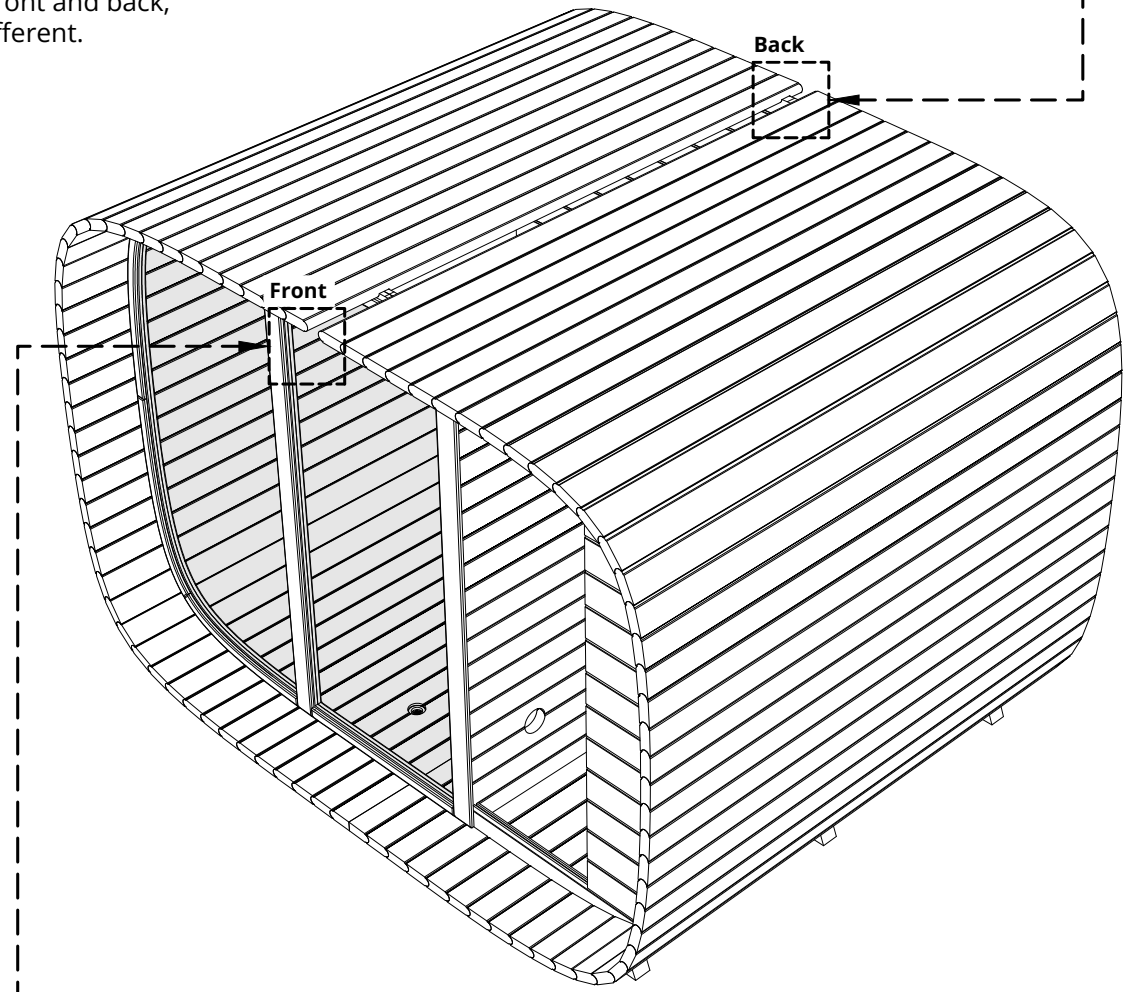

S2...7	Screws 3x40 ... 4,5x80	x7
		

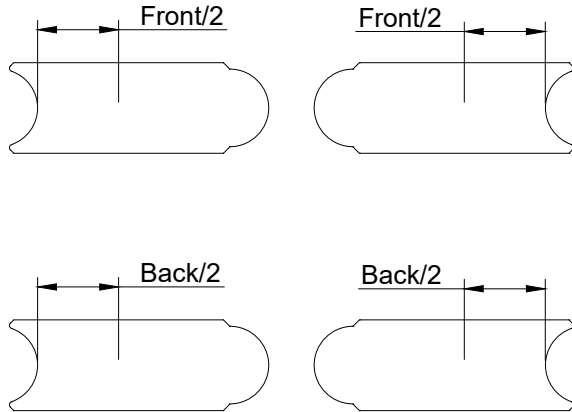

Divide the measurement by two and transfer the measurements to the last two planks. Connect the dimensions on the plank with a line and cut off these ends.

Glue the two freshly cut boards with wood glue and connect them with 7 pieces of 3x40 ... 4.5x80 screws (the length of the screws depends on the final width of the last two planks cut). Wipe off excess glue with a cloth and then use sandpaper to smooth out the gap.

Please countersink the screw head!

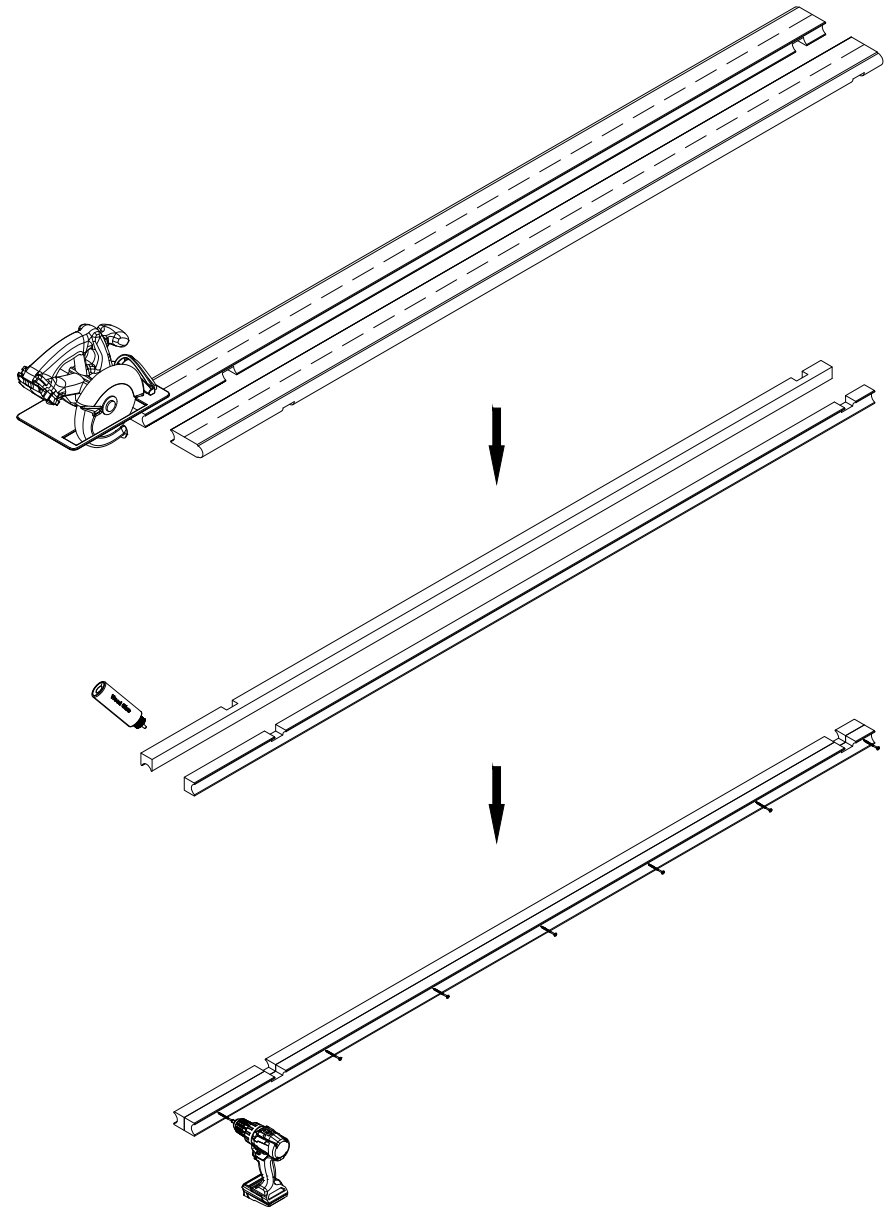

S5	Screws 4,5x60 for Spruce Screws 4,2x55 for Thermo	x6
		

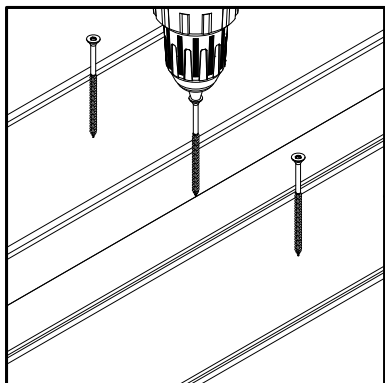
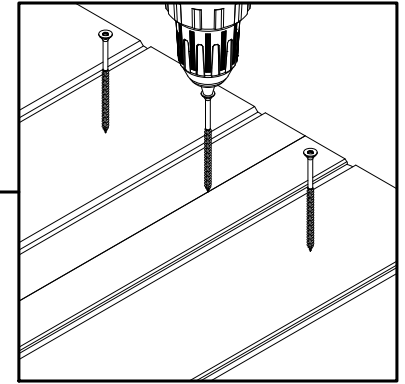
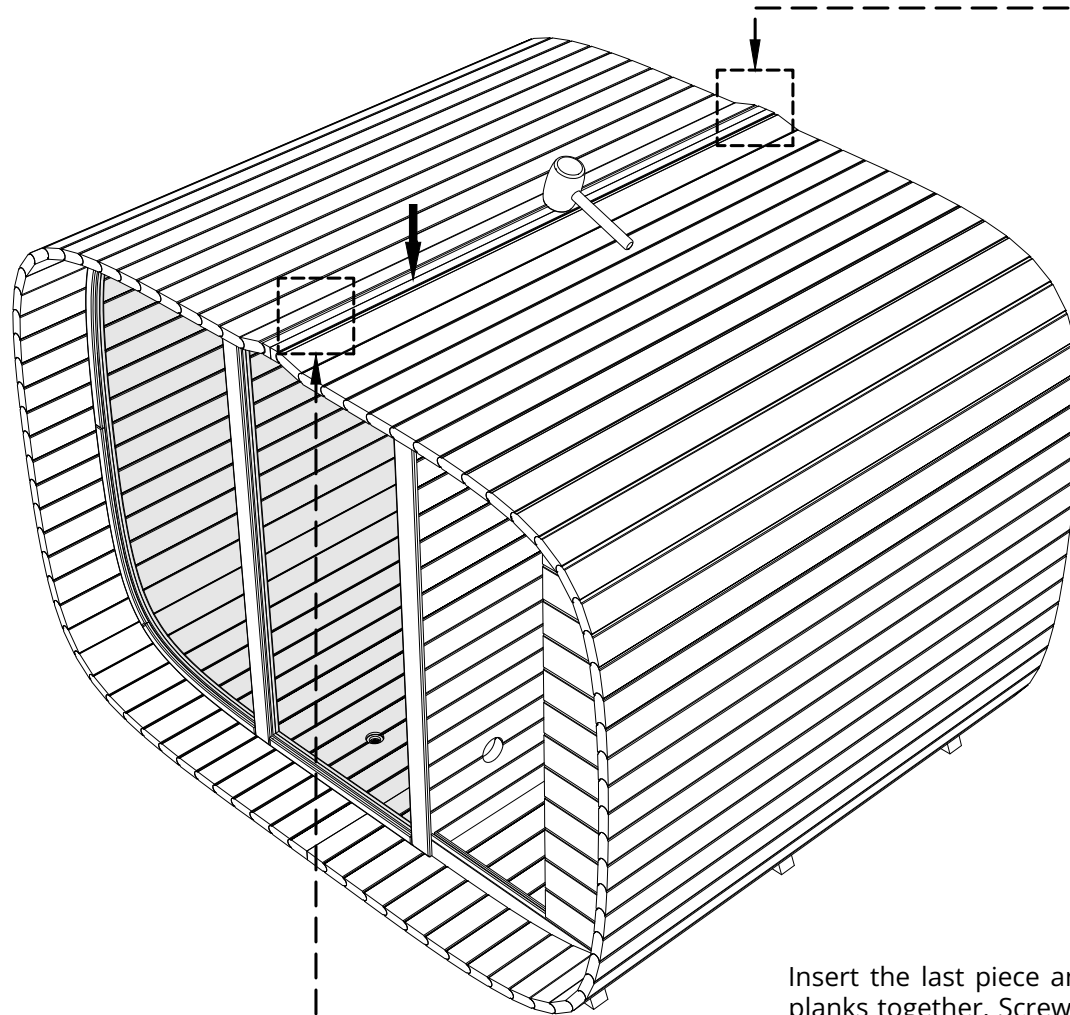

Insert the last piece and use a rubber mallet to tap the planks together. Screw the loose planks to the walls with screws.

Please countersink the screw head!

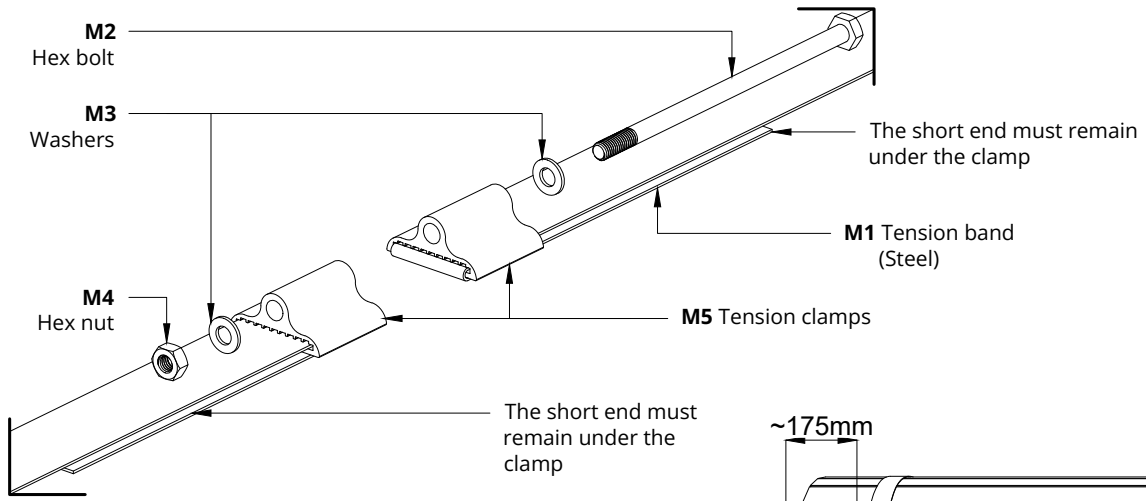

Place the tension bands M1 (Steel band) around the side walls and thread the bands into the eyelet as follows (see sketch above).

Hex nuts and bolts must be tightened as long as the planks are stationary in all directions.

The tension band and clamps must be placed as shown in the picture below.

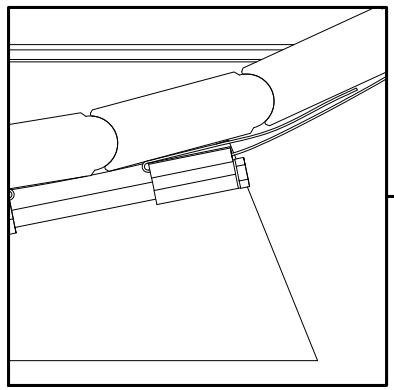
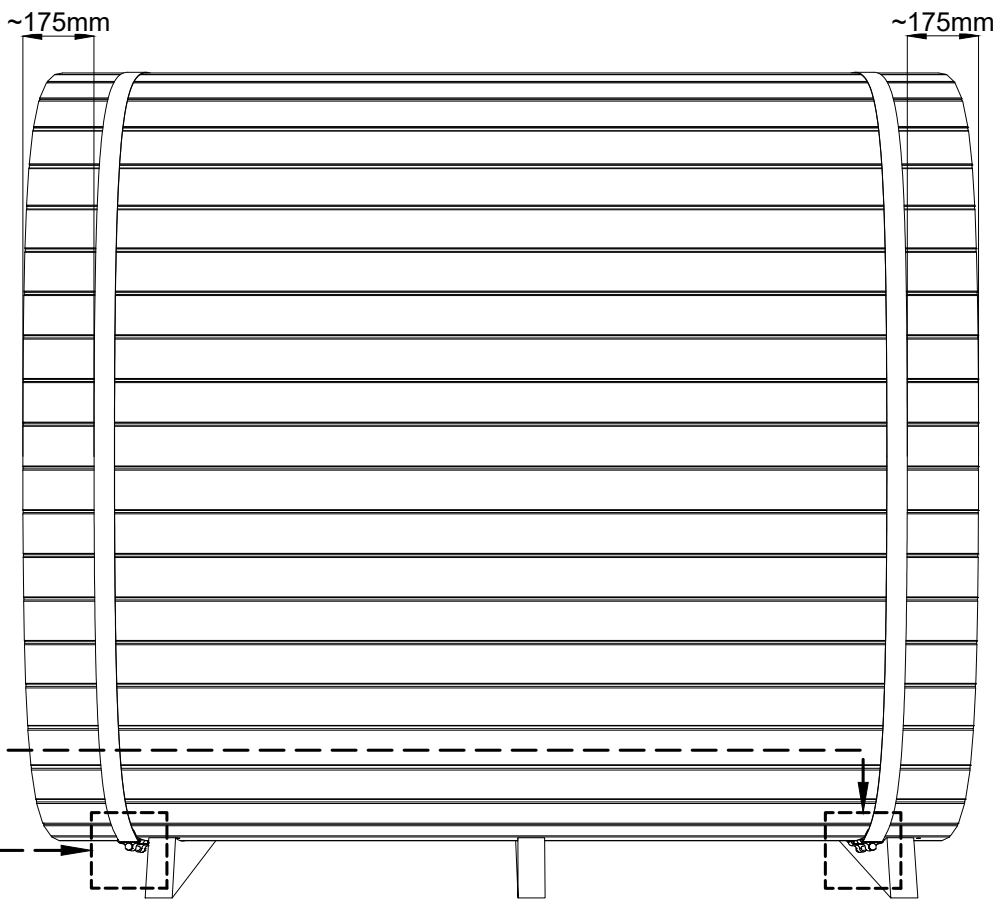

S1	Screws 3x30	x30
		

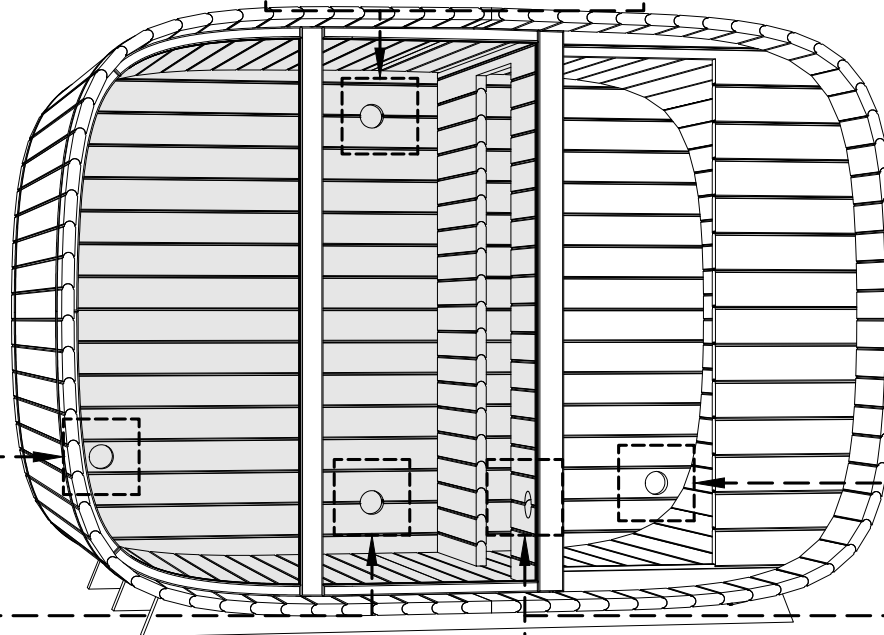
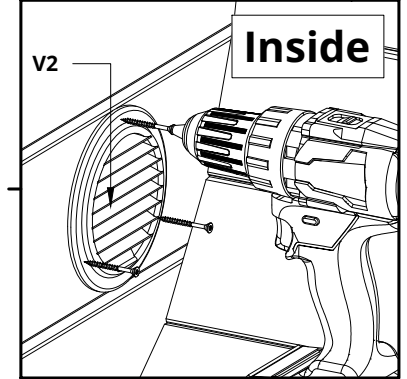
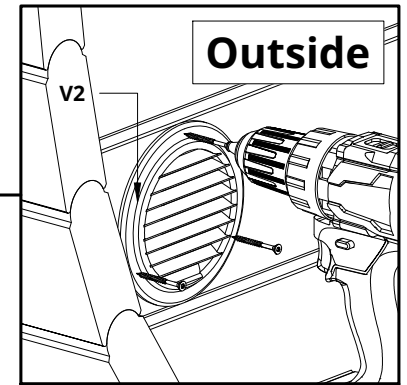
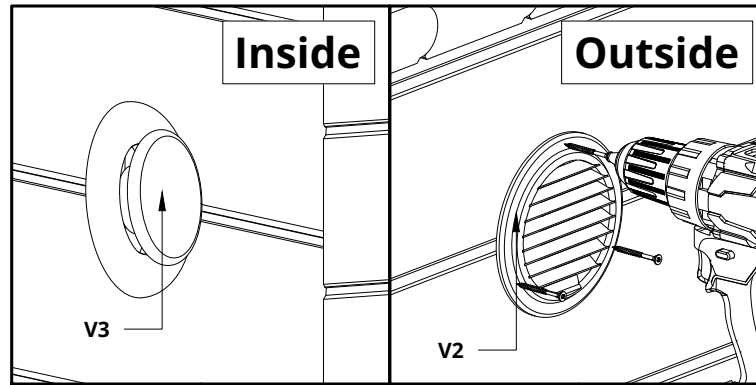
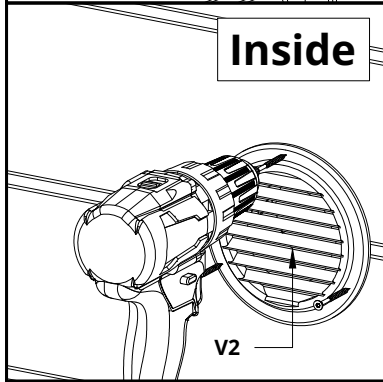
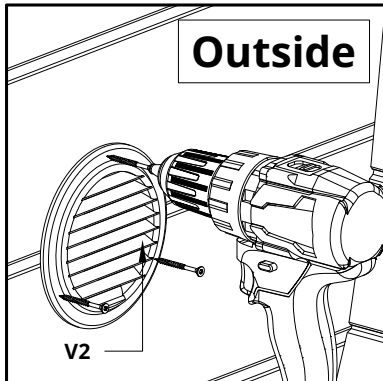

The inner and outer ventilation grilles V2 and adjustable cover V3 are screwed with 3 screws.

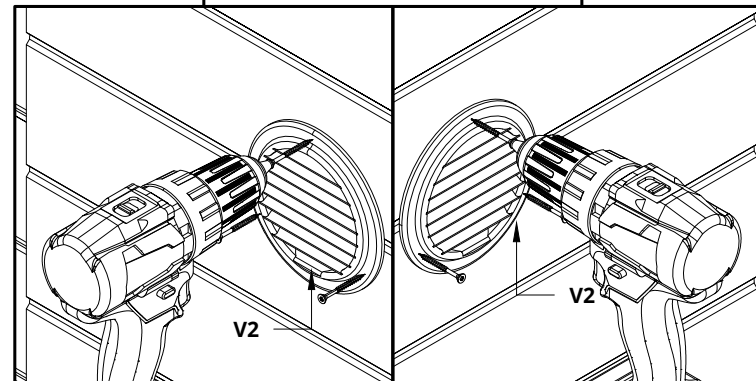
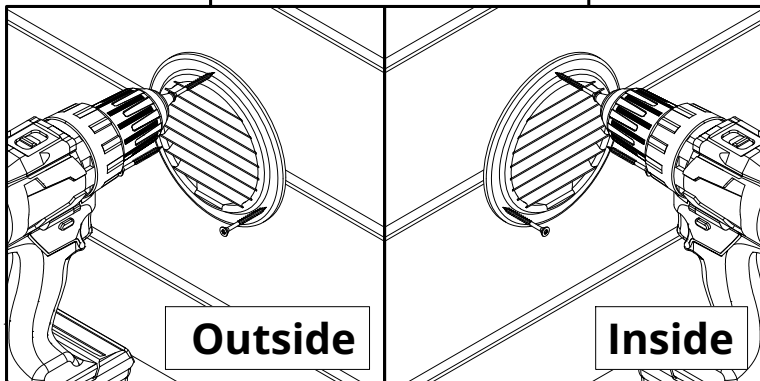

S6.2	Screws 4,2x75	x15
S2	Screws 3x40	x11
		

NB! use a level

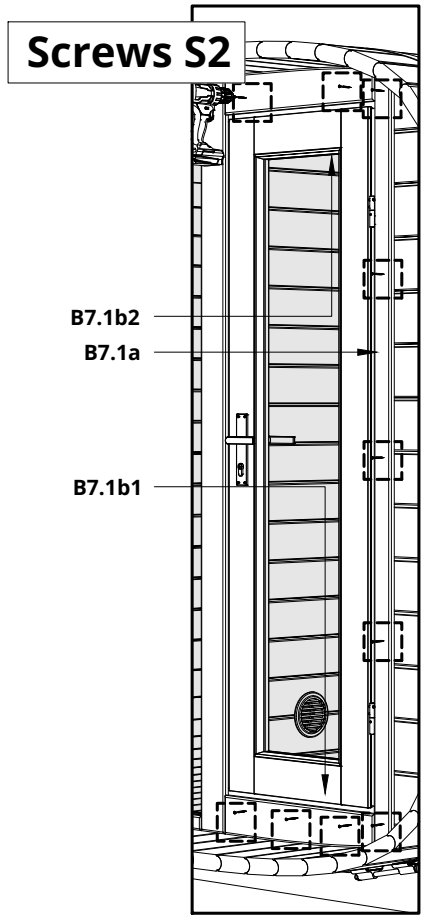
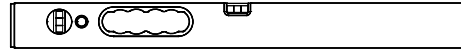

Screws S2

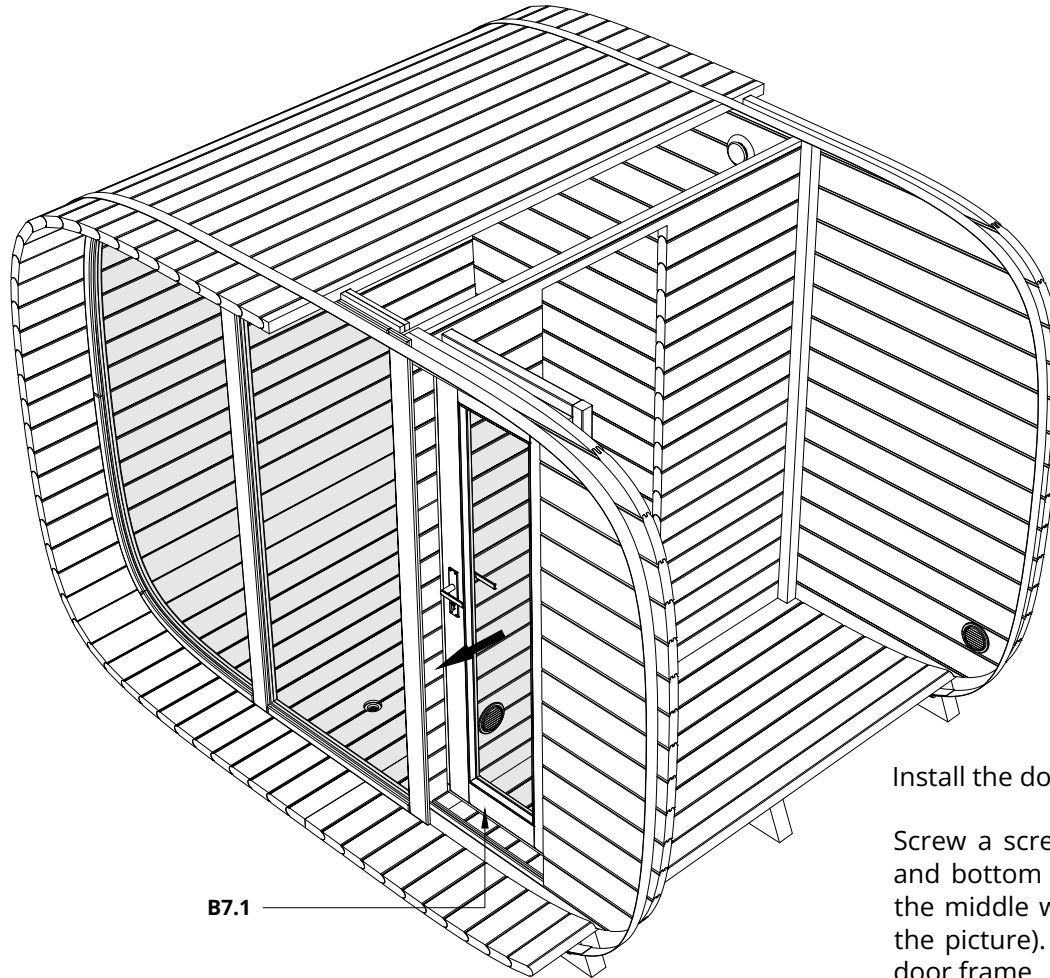

Screws S6.2

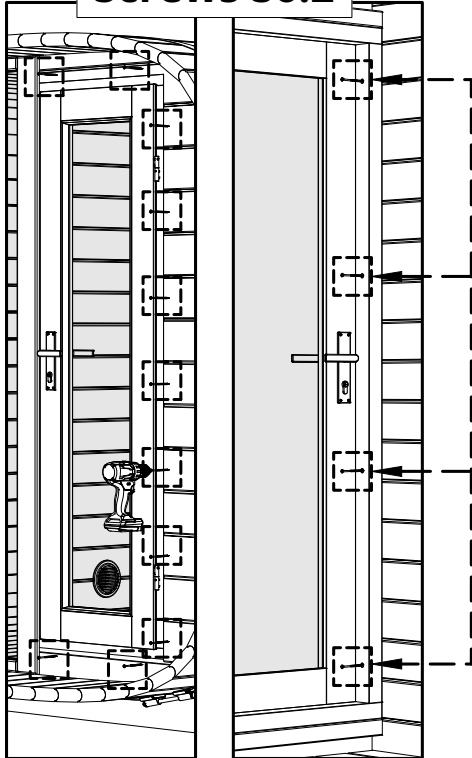

B7.1

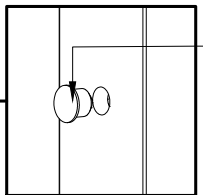

D1

Install the doors from inside (shown in the picture).

Screw a screw into every second plank, 2 screws top and bottom and to the door frame that rests against the middle wall that has 4 holes for screws (shown in the picture). Cover the four holes with a dowel in the door frame.

If the door is in place, install the door lath, top with 2 screws and bottom with 3 screws and the side with 5 screws.

Please countersink the screw head!

S6.2	Screws 4,2x75	x20
S2	Screws 3x40	x13
		

NB! use a level

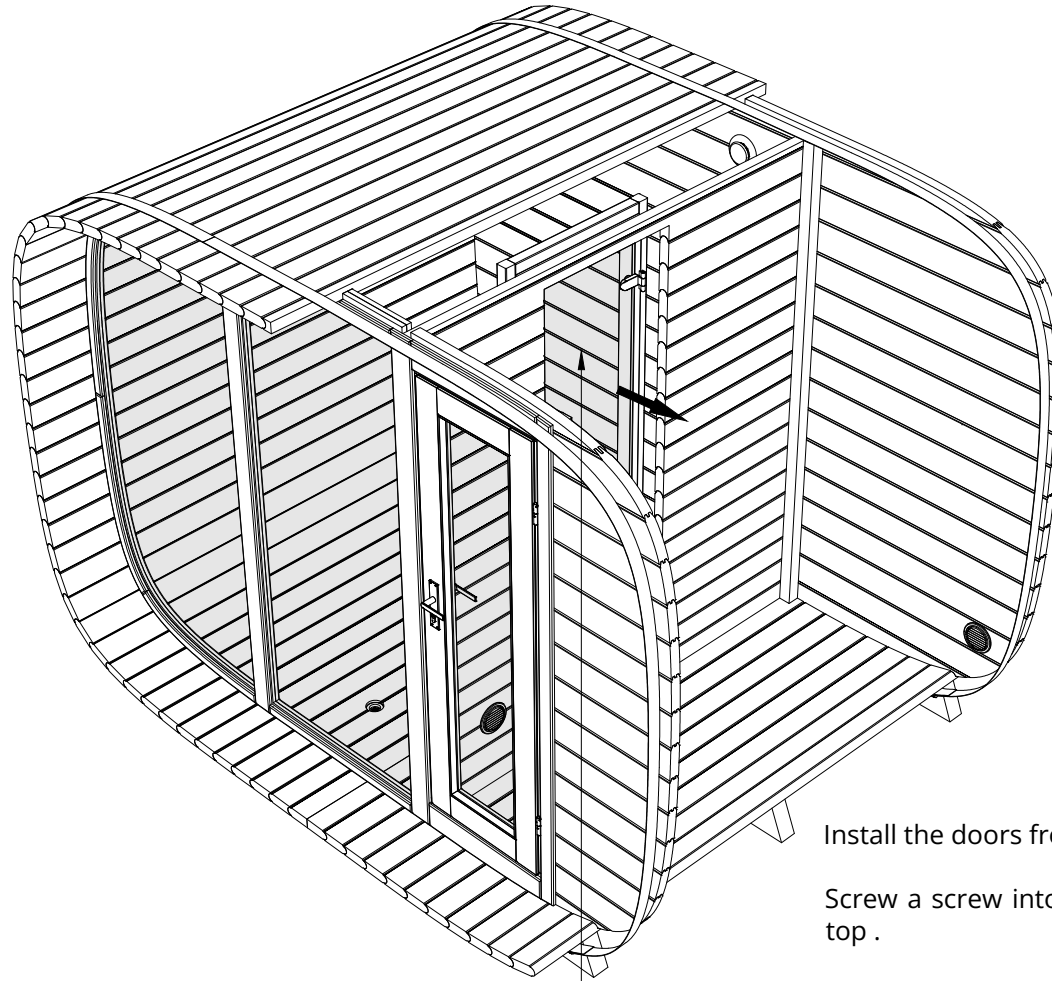
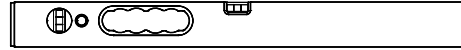

B7.2

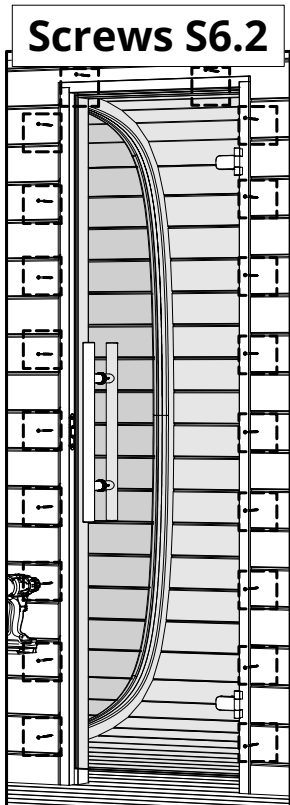
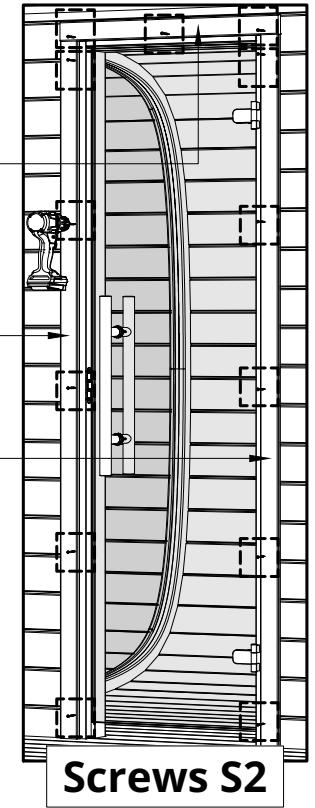

Install the doors from inside (shown in the picture).

Screw a screw into every second plank and 2 screws top .

If the door is in place, install the door lath, top with 3 screws and the sides with 5 screws.

Please countersink the screw head!
Recommended! Drill small holes for the lath screws.

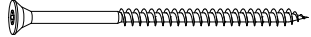
S1	Screws 3x30	x20
		

To install the cover strip, use screws (which are included) or use lath nails (which are not included, you have to provide them yourself).

The best result is obtained with nails, their heads are less visible.

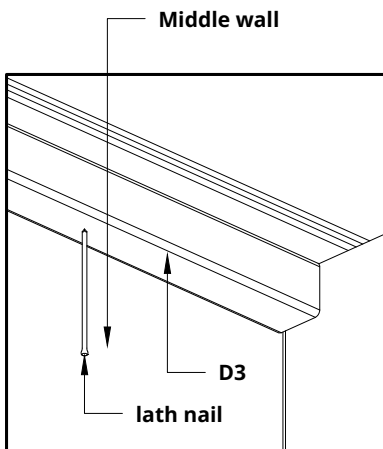
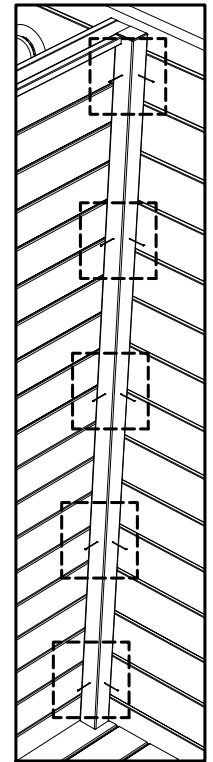
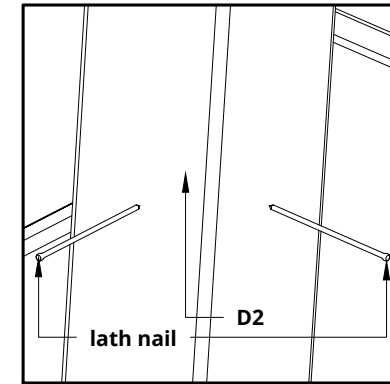
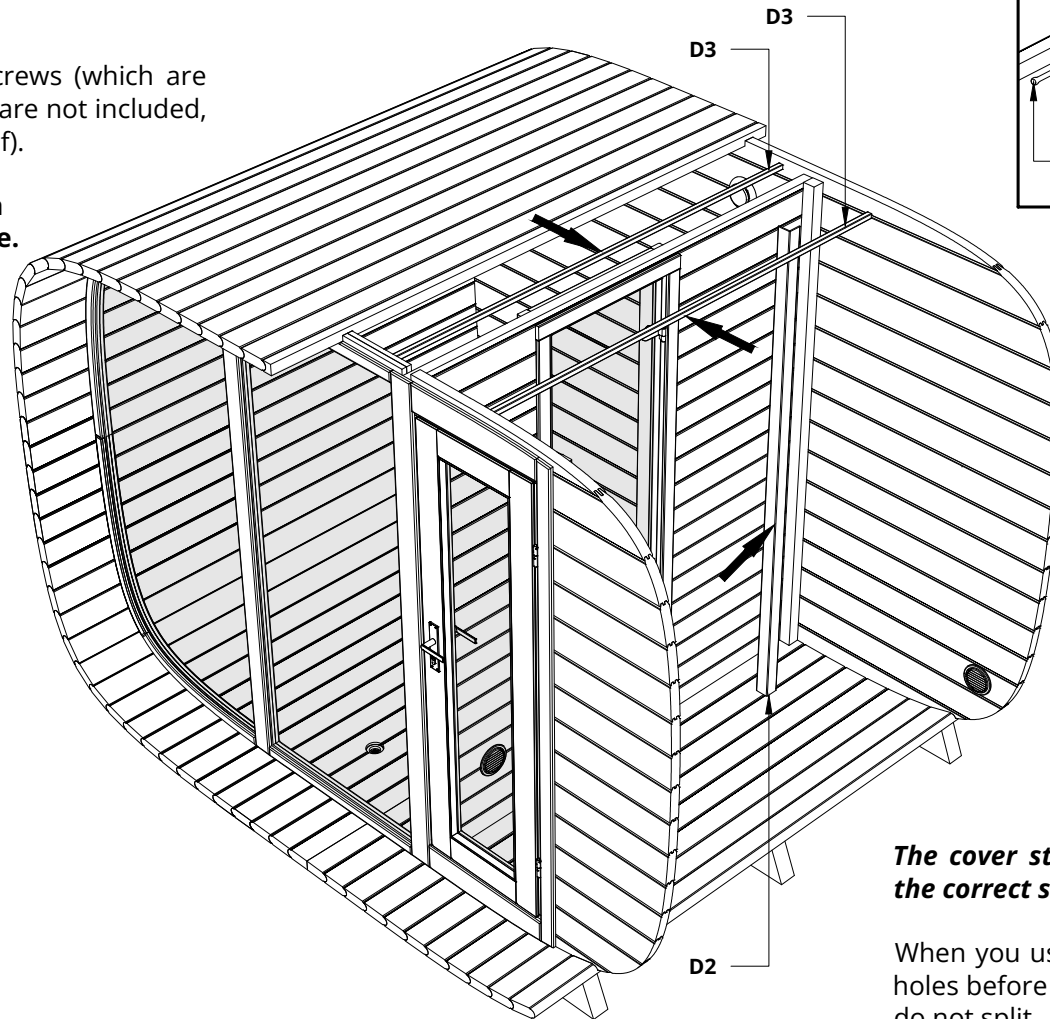

The cover strips are longer, they must be cut to the correct size.

When you use screws, it is necessary to drill small holes before screwing the cover strips, so that they do not split.

D3 are fixed with 5 screws or 5 lath nails to the ceiling. D2 is fixed with 10 screws or 10 lath nails.

Please countersink the screw head when using screws!

R5	Nail 2,5x25
	

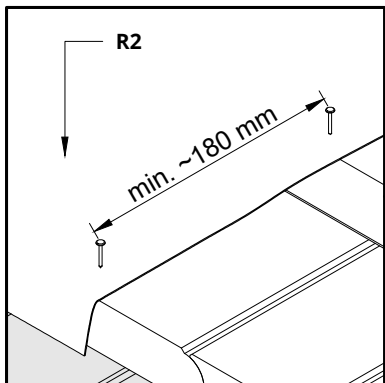
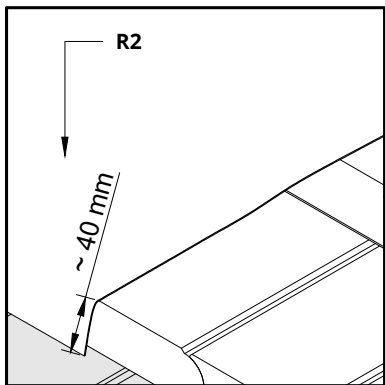
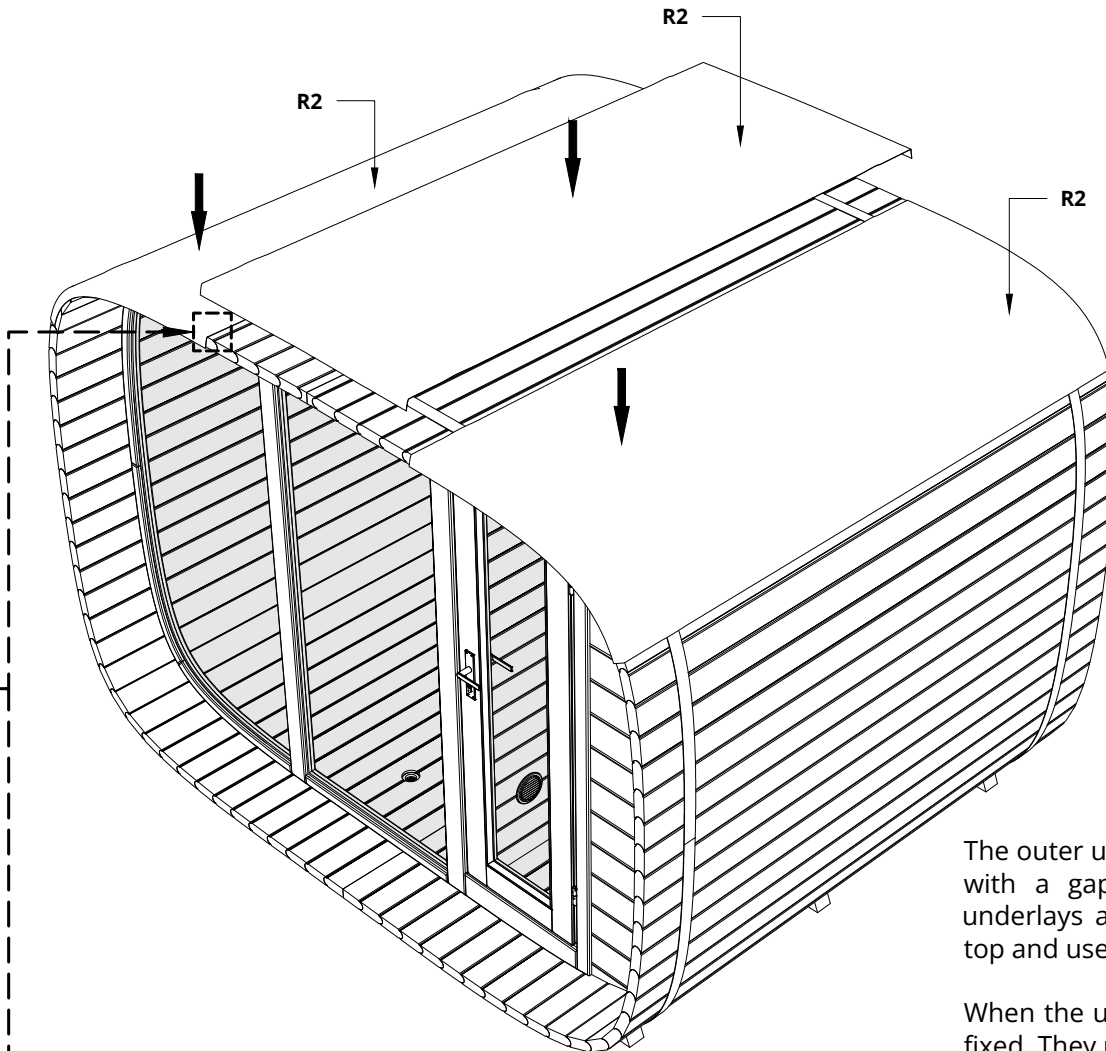
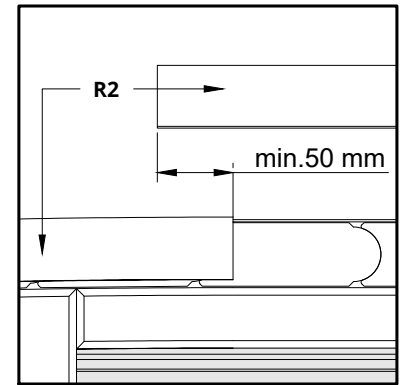

Install first outer underlayment so that the middle underlay overlaps the outer ones by at least 50 mm to cover the nail heads.

The underlay must extend over the front end and back end by 40 mm.

The outer underlays are fixed with nails from the top, with a gap of about 180 mm. When the outer underlays are in place, put the middle underlay on top and use a heat source to make it stick.

When the underlays are in place, their ends must be fixed. They must be bent before fixing with nails.

Use a heat source when you bend them, otherwise they may break or leave cracks.

R5	Nail 2,5x25
	

The base sheet of the first row must be installed first.

Sheets are self-adhesive, for better adhesion use a heat source.

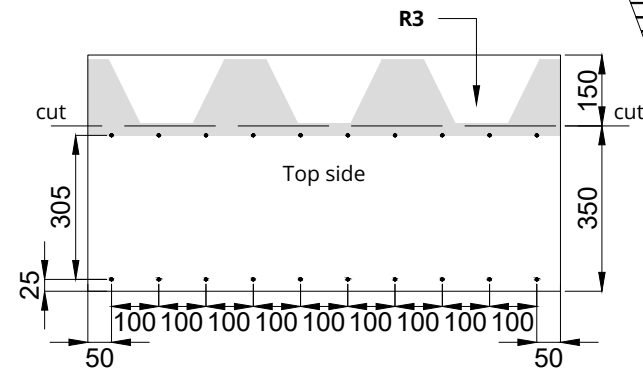
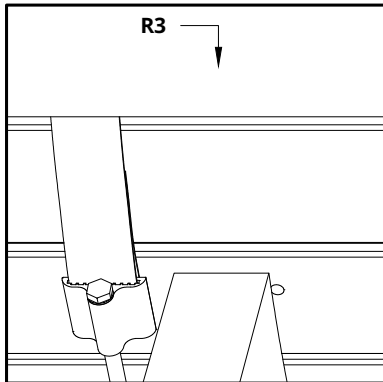
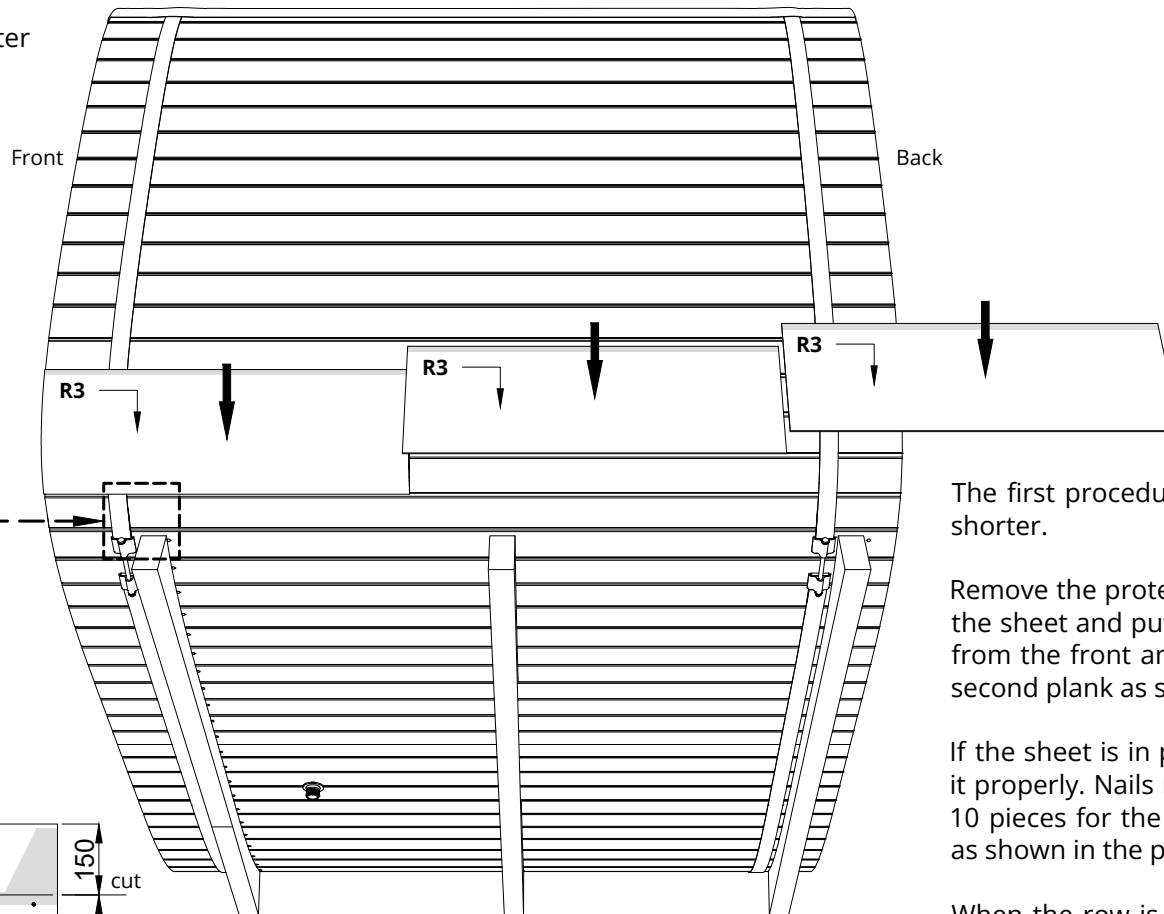
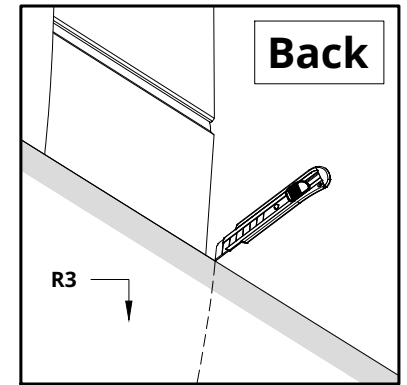

The first procedure is to cut the sheet 150 mm shorter.

Remove the protective films from the bottom of the sheet and put it in place by starting the row from the front and bottom of the sauna on the second plank as shown in the pictures.

If the sheet is in place, nails must be used to fix it properly. Nails must be placed every 100 mm, 10 pieces for the whole sheet below and above as shown in the picture.

When the row is finished and extends over the edge, it must be cut off and the leftovers can be used to complete the row on the other side.

Repeat these steps on the other side as well!

R5	Nail 2,5x25
	

The first sheet of the first row starts from the bottom and center of the side wall of the sauna.

Sheets are self-adhesive, for better adhesion use a heat source.

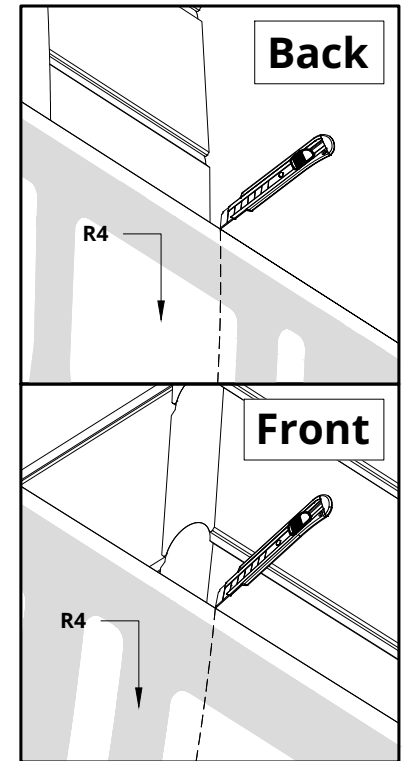
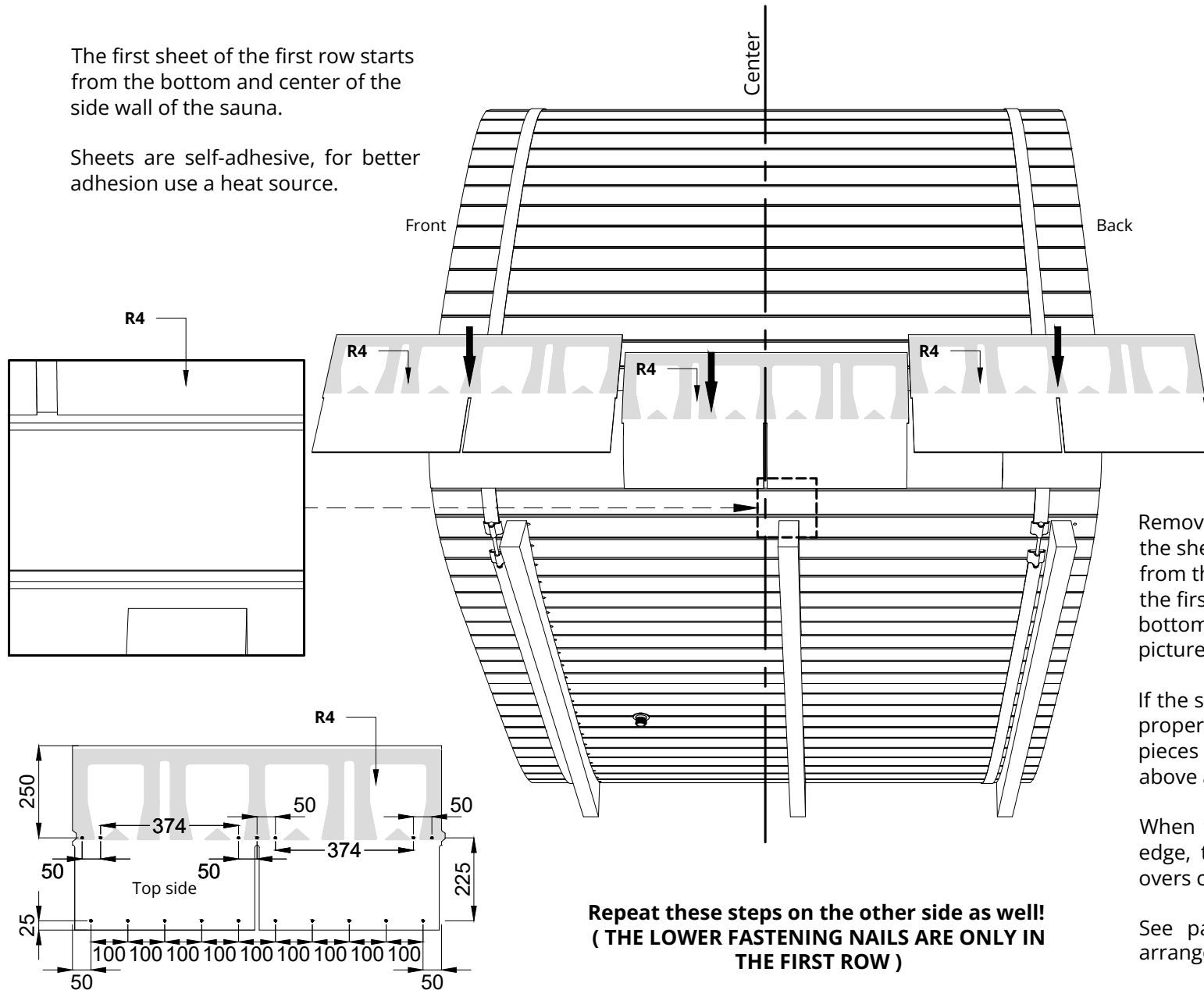

Remove the protective film from the bottom of the sheet and put it in place by starting the row from the bottom and center. The bottom edge of the first row sheet must be in line with the bottom edge of the base sheet shown in the pictures.

If the sheet is in place, nails must be used to fix it properly. Nails must be placed every 100 mm, 10 pieces for the whole sheet below and 7 pieces above as shown in the picture.

When the row is finished and extends over the edge, the excess must be cut off and the left-overs can be used in the following rows.

See page 28 for a recommendation on row arrangement.

**Repeat these steps on the other side as well!
(THE LOWER FASTENING NAILS ARE ONLY IN
THE FIRST ROW)**

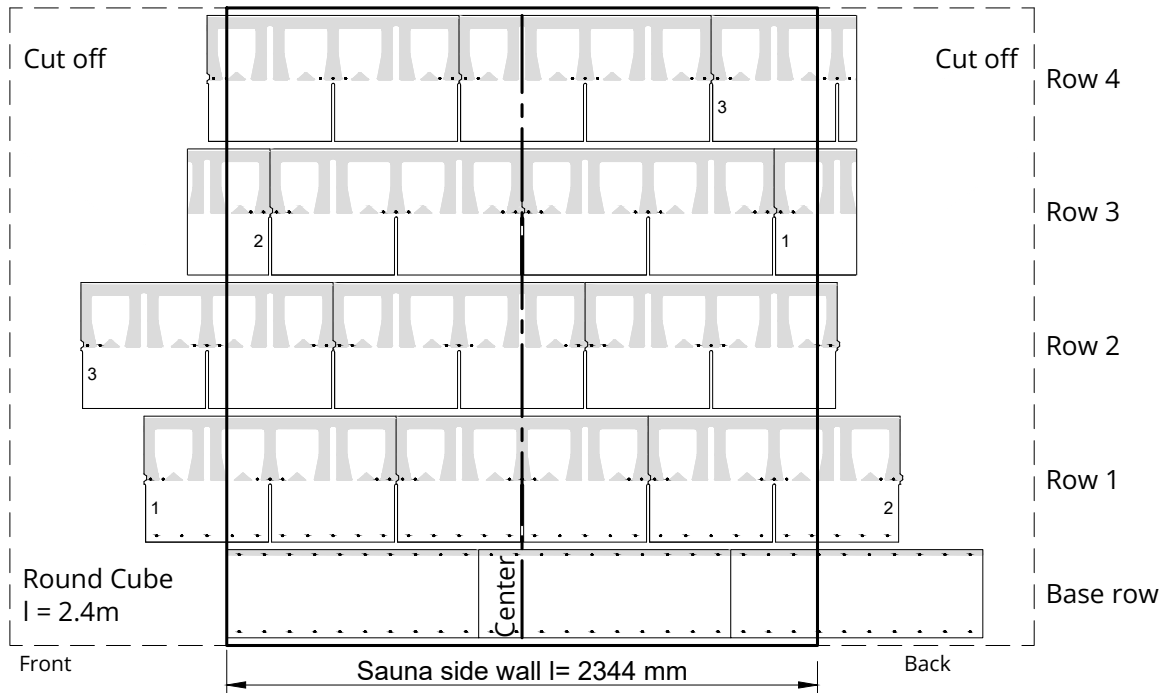

Bitumen roof sheet row arrangement for Round Cube 2.4 and 2.6

The base row is installed first, then the first row, etc. up in the middle of the sauna. The sheets that remain over the edge of the sauna wall are cut off and, if possible, used for other rows.

The base row starts at the front end of the sauna, row 1 always starts in the middle, the other rows are offset from the middle.

For row 1, use nails to fix the lower end, and for row 2, use the included bitumen silicone. Subsequent rows from the second row do not need fix from lower end.

The layout pattern repeats every 4 rows.

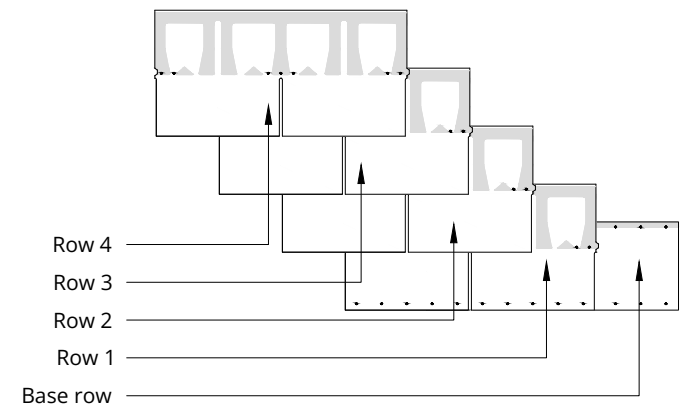
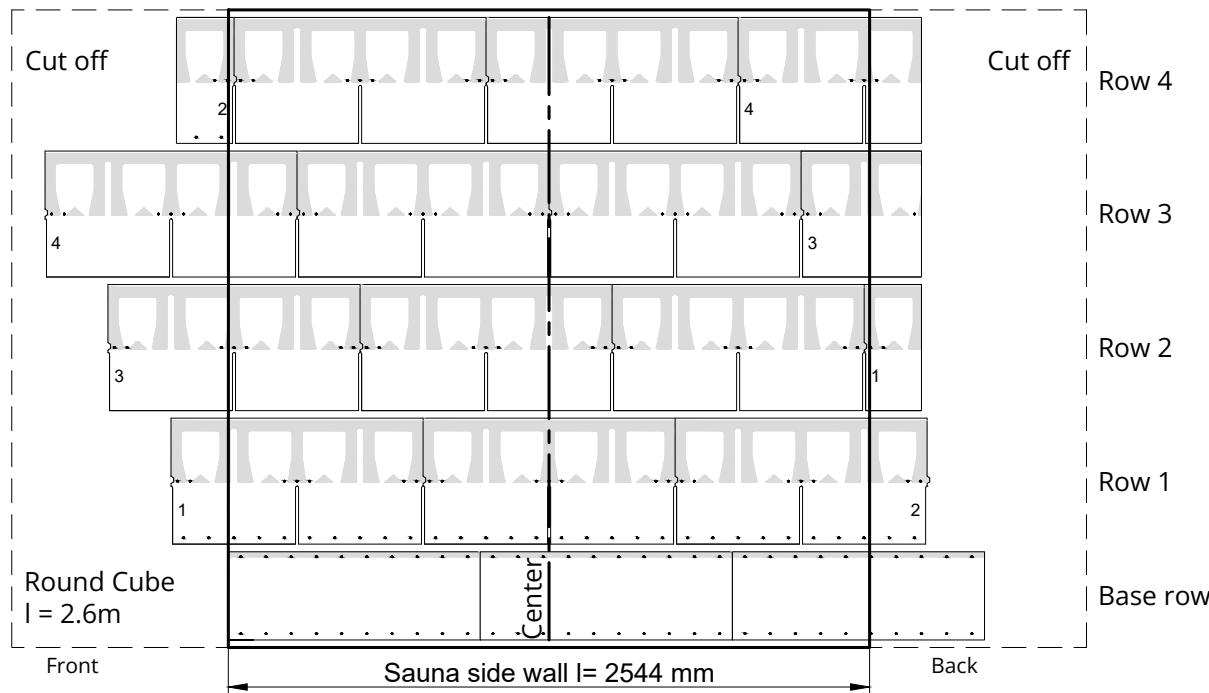

R5	Nail 2,5x25
	

The roof ridge must be placed in the middle, starting from the back end of the sauna or from the front end.

Sheets are self-adhesive, for better adhesion use a heat source.

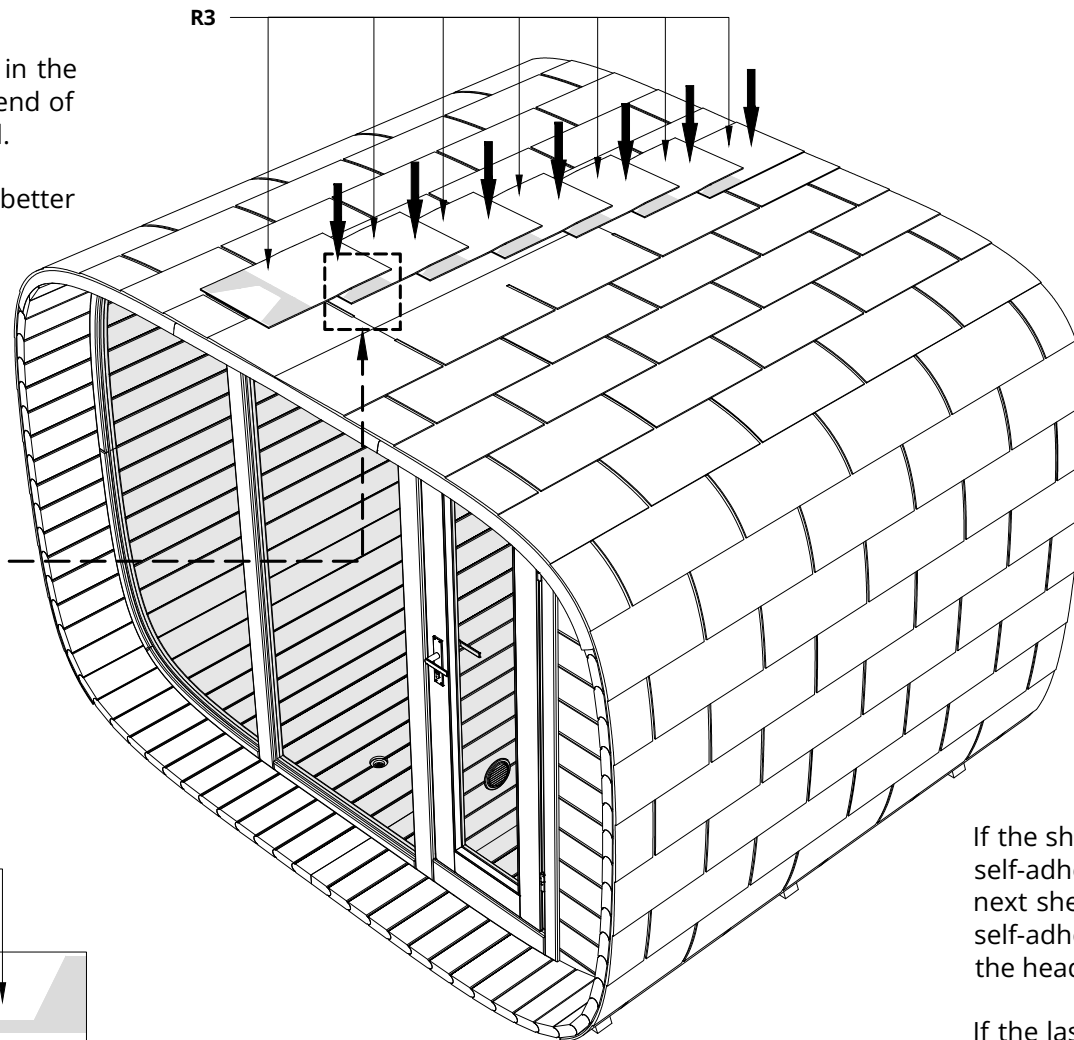
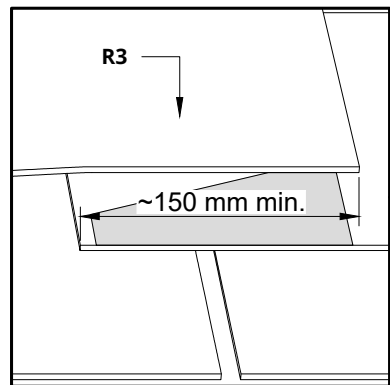
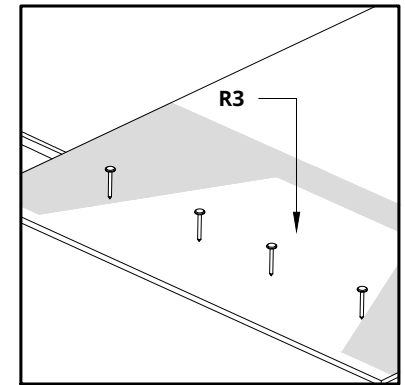

If the sheet is in place, fasten it with 4 nails on the self-adhesive spot as shown in the picture. The next sheet must be placed so that it overlaps the self-adhesive spot of the first sheet and covers the head of the nail min. length 150 mm.

If the last sheet extends over the edge, it must be cut off, and if the self-adhesive part remains visible, it must be covered with a suitable piece of excess, use bitumen silicone for fixing.

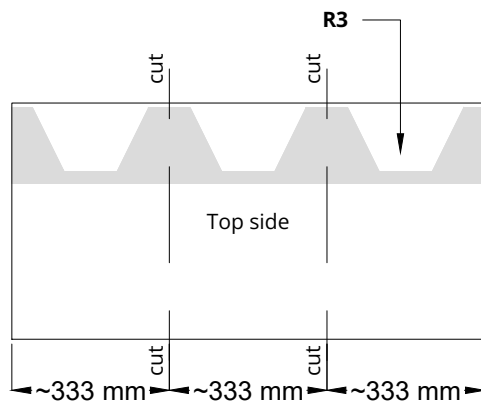

The first procedure is to cut the sheet into three pieces.

Remove the protective film from the sheet and put it in place by starting the ridge row from back end of the sauna or from the front end.

S6.1	Screws 4,5x70 (black coated)	x60
		

NB! use a level

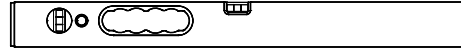

Installation of cover boards at the front end and at the back end of the sauna.

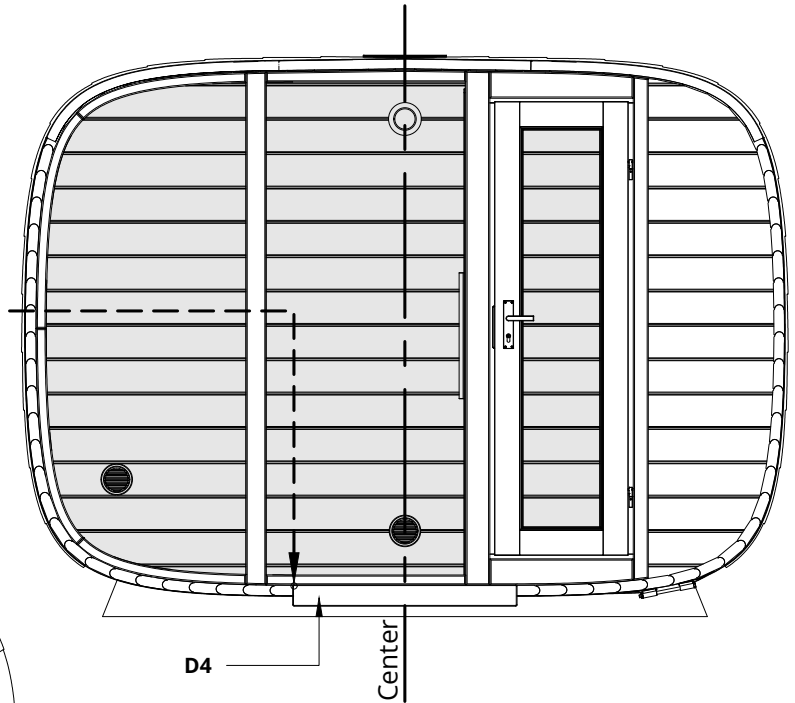
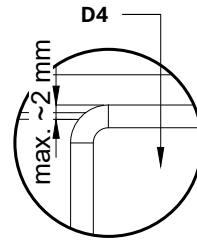
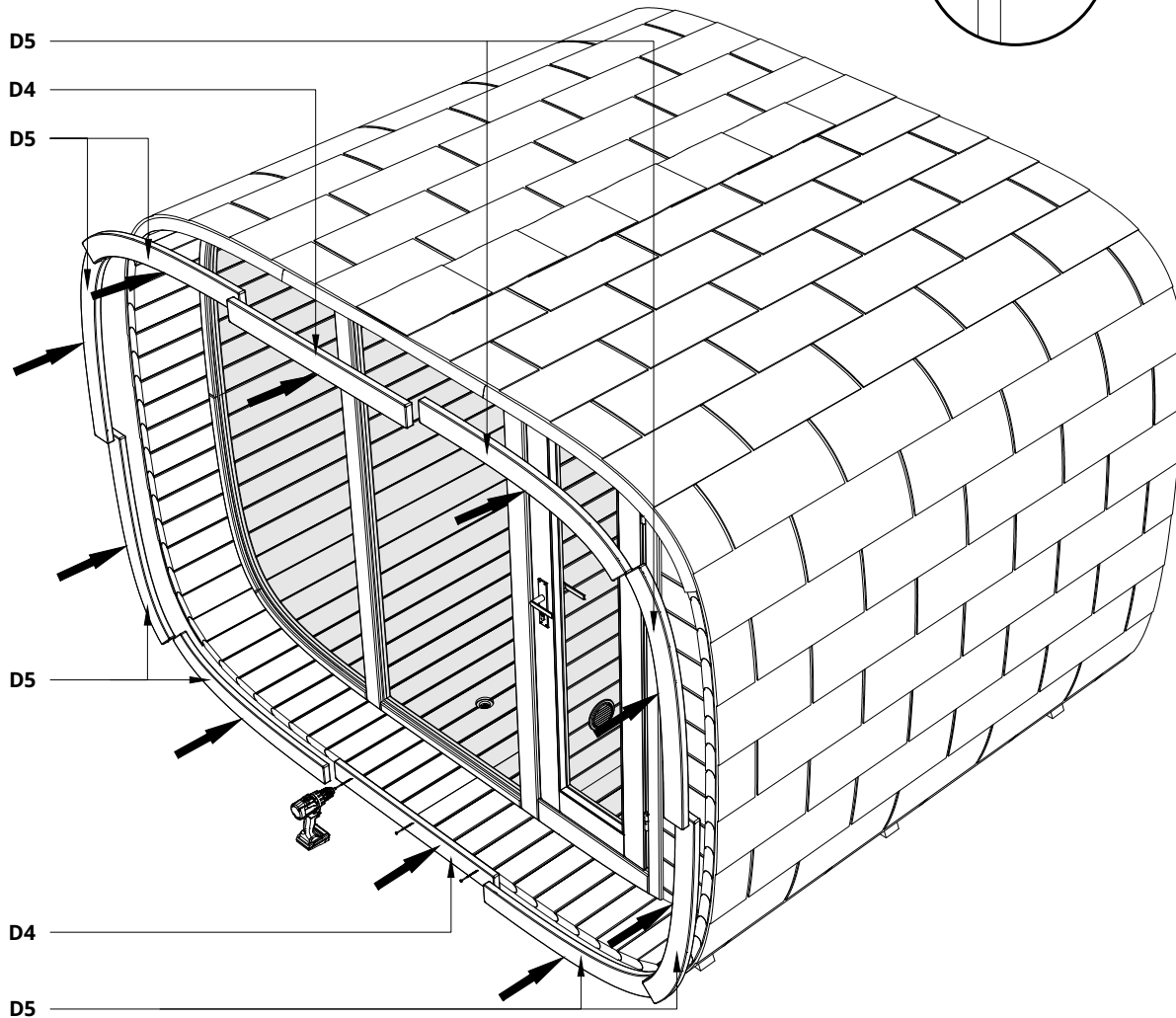

The installation of the cover boards is started from the bottom and the first cover board must be in the center at the front end and at the back end of the sauna.

The upper edge of the first cover board must be at the same height as the floor. It can also be a little higher than the floor level, but not more than 2 mm.

Glue must be added to the lower 3 cover boards before screwing. Each cover board is screwed with 3 screws.

If the front end of the sauna is done, the back end of the sauna must be done in the same way.

Please countersink the screw head!

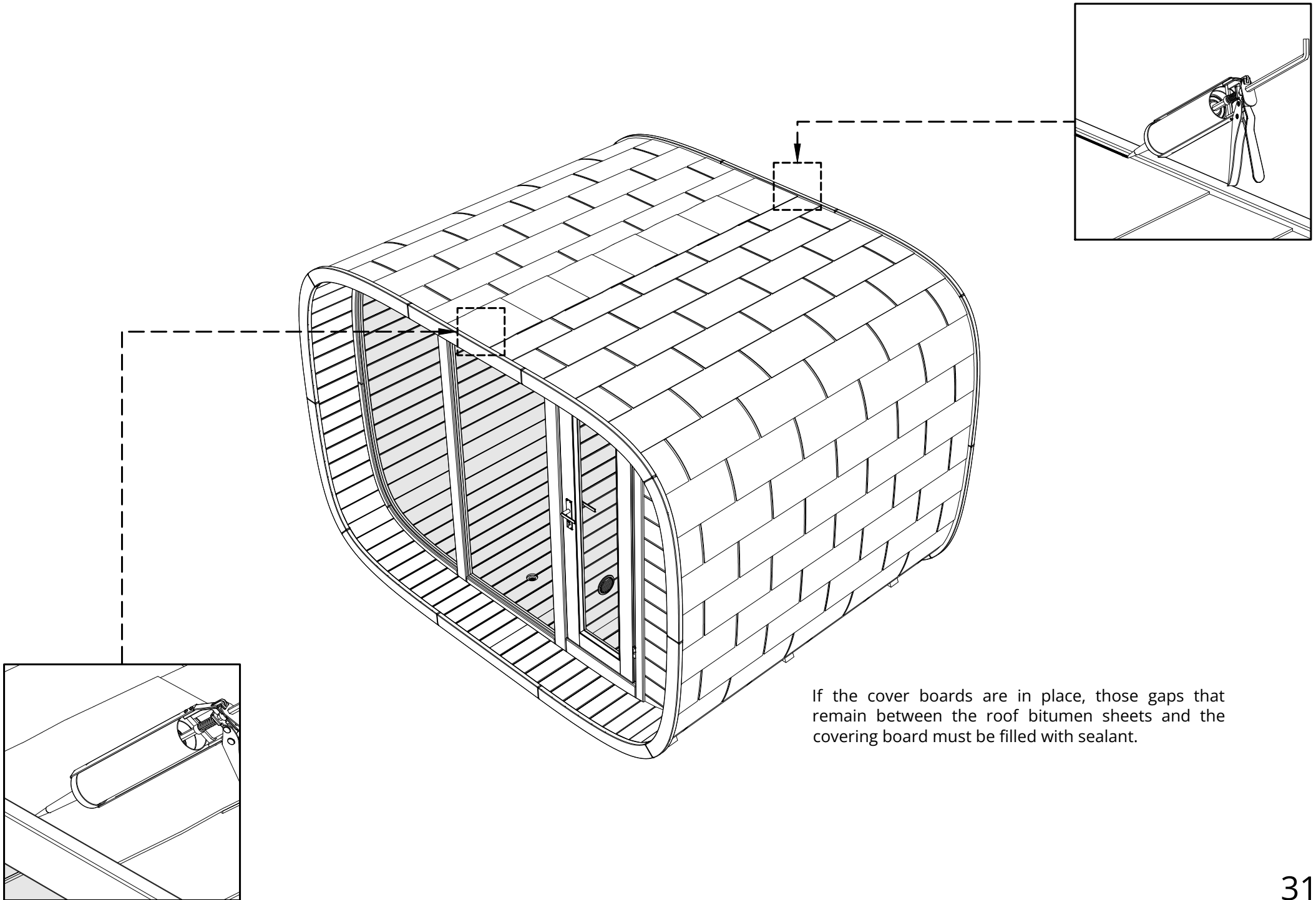

If the cover boards are in place, those gaps that remain between the roof bitumen sheets and the covering board must be filled with sealant.

S7	Screws 4,5x80 for Spruce Screws 4,2x75 for Thermo	x8
		

NB! use a level

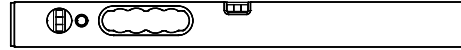

Notice!

Drill 4mm hole in the K.. square woods before screwing.

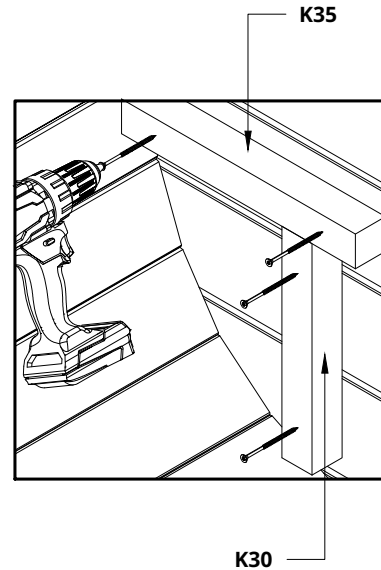
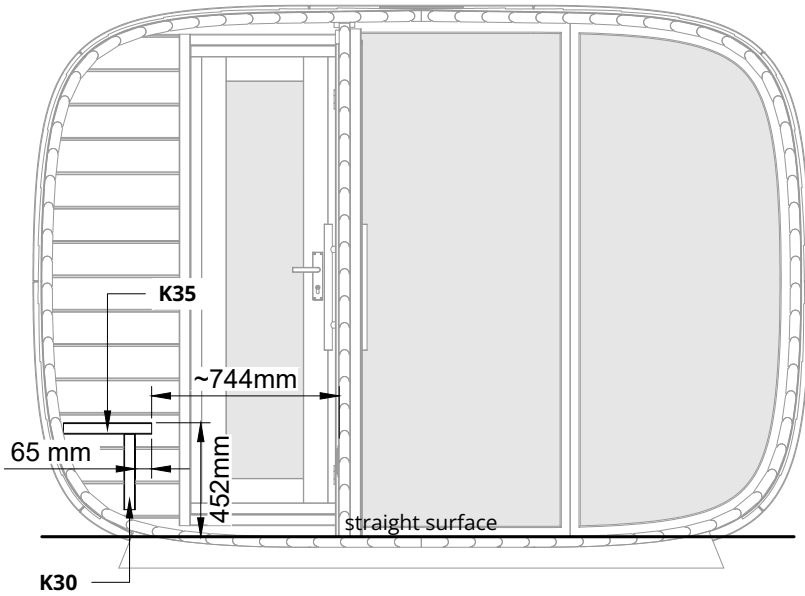
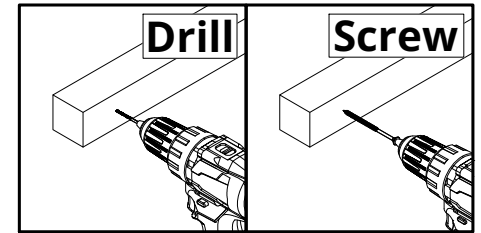

Height measurements are measured from a straight surface.

Please countersink the screw head!

First, measure the height of the K35 wall mount of the bench. The upper edge height of K35 is shown in the picture.

Next, install the bench skirt wall mount K30. Install K30 exactly under K35 making sure it is perpendicular. The depth of the outer edge of K30 is measured from K35 is shown in the picture.

Before installing square wood K30 and K35, drill holes for screws. Add glue and then screw it to the wall and wipe off the excess glue.

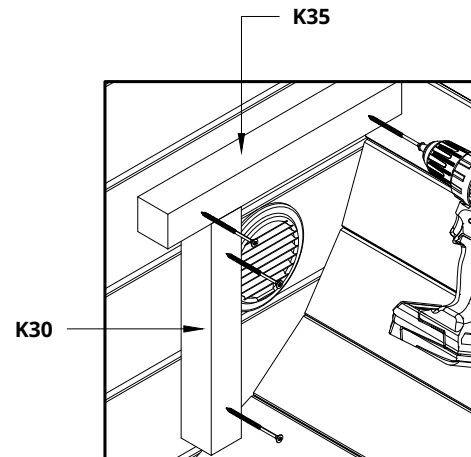
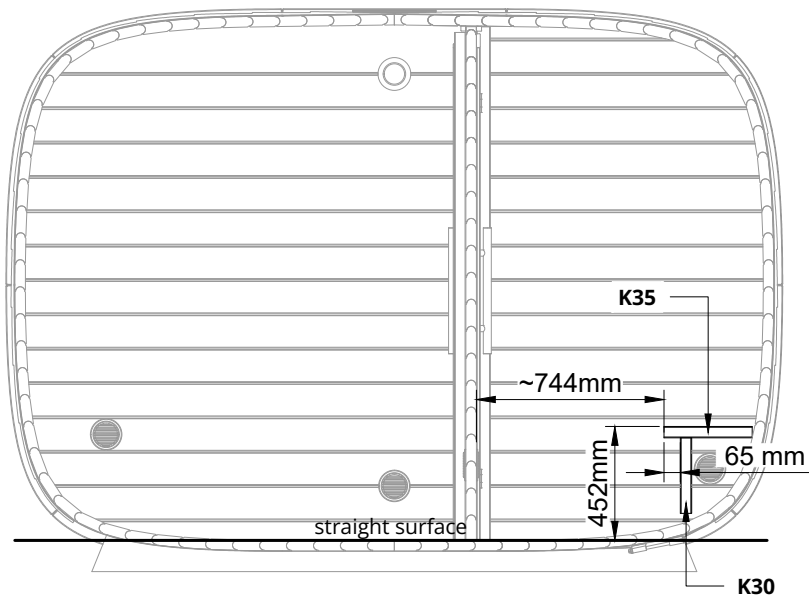

S5	Screws 4,5x60 for Spruce Screws 4,2x55 for Thermo	x4
S7	Screws 4,5x80 for Spruce Screws 4,2x75 for Thermo	x8
		

NB! use a level

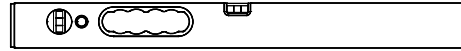

Notice!

Drill 4mm hole in the K10 square wood before screwing.

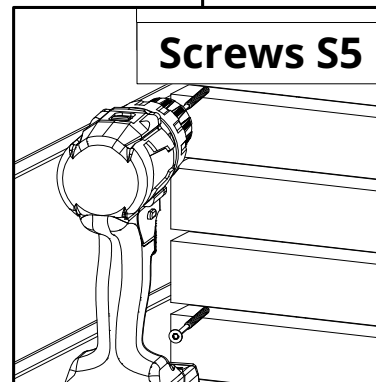
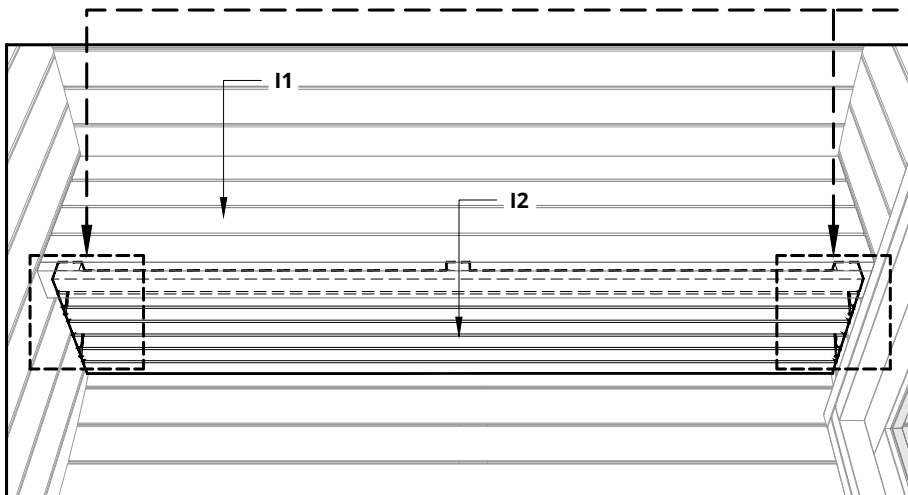
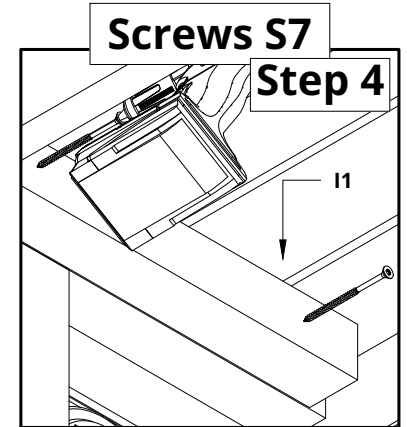
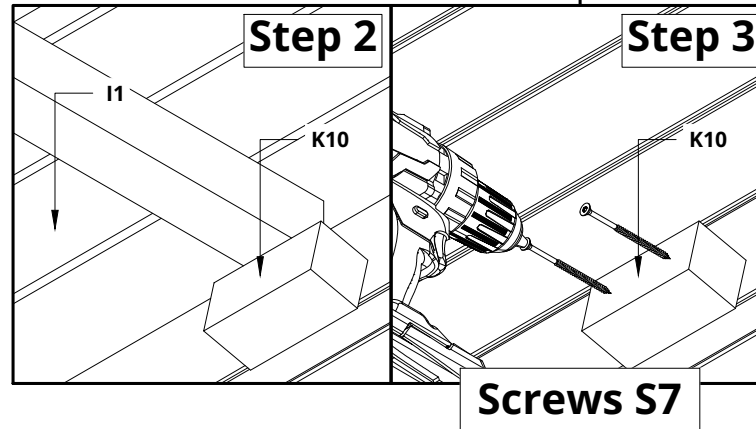
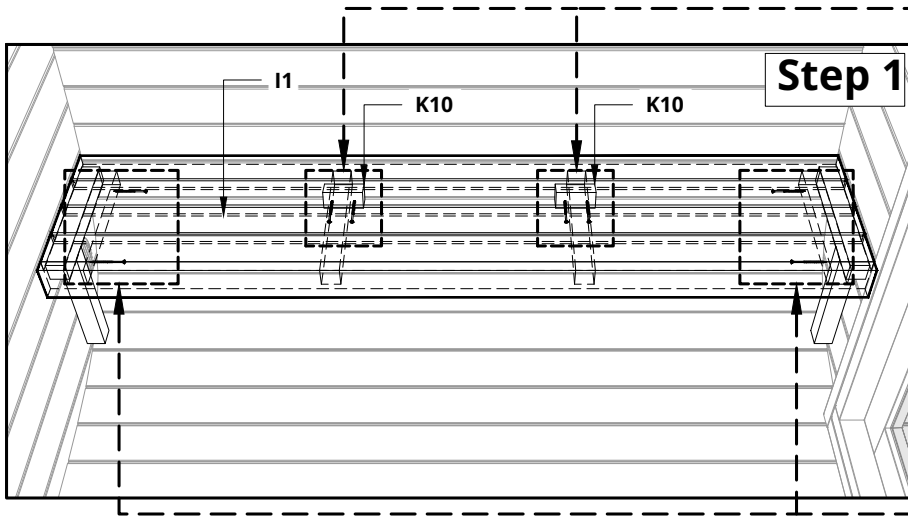
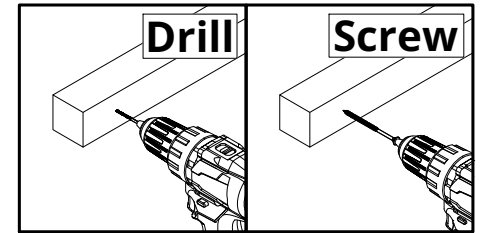

- Step 1: Place the I1 bench, but do not screw it to the wall mounts K35.
- Step 2: Take the square wood K10, place it under the bench as shown in the picture, mark its location.
- Step 3: If marked, move the bench away to install K10, add a little glue, screw it to the wall where it was marked.

Put the bench I1 back and fasten it to the wall mount K35 with screws.

Now install the bench skirt, and fasten it to the previously installed wall mounts K30.

S7	Screws 4,5x80 for Spruce Screws 4,2x75 for Thermo	x8
		

NB! use a level



Notice!

Drill 4mm hole in the K.. square woods before screwing.

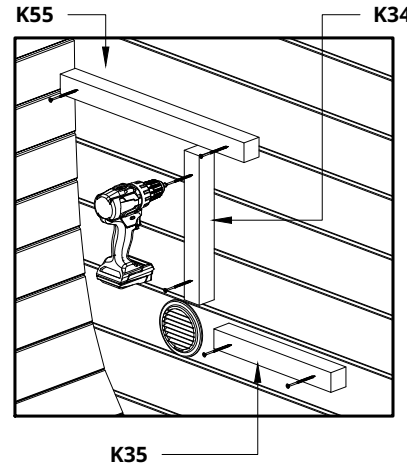
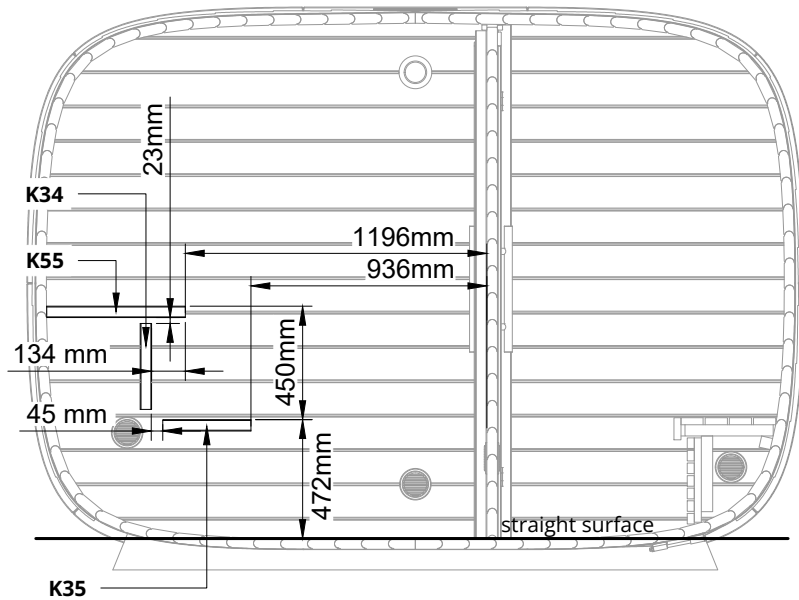
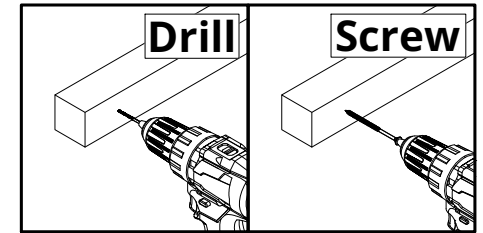

Height measurements are measured from a straight surface.

Please countersink the screw head!

First measure and install wall mount K35. Measure the height and distance from the middle wall. The upper edge height and distance from the middle wall of K35 is shown in the picture.

Next measure and install K55. Measure the upper edge of the wall mount K55 from the wall mount K35 and the distance from the middle wall.

Next measure and install bench skirt wall mount K34. Measure the upper edge of the wall mount K34 and the outer edge depth distance from the wall mount K55. The K34 wall mount should be perpendicular to the K55 wall mount.

Now measure and install K30. Measure the height and distance from the back wall.

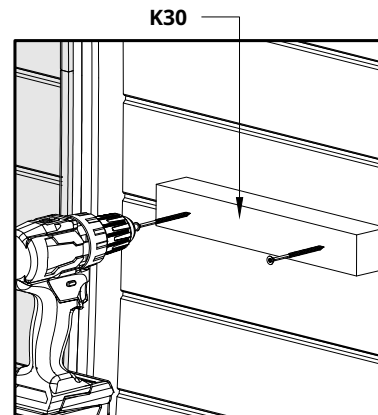

Before installing square wood K30, K34, K35 and K55, drill holes for screws. Add glue and then screw it to the wall and wipe off the excess glue.

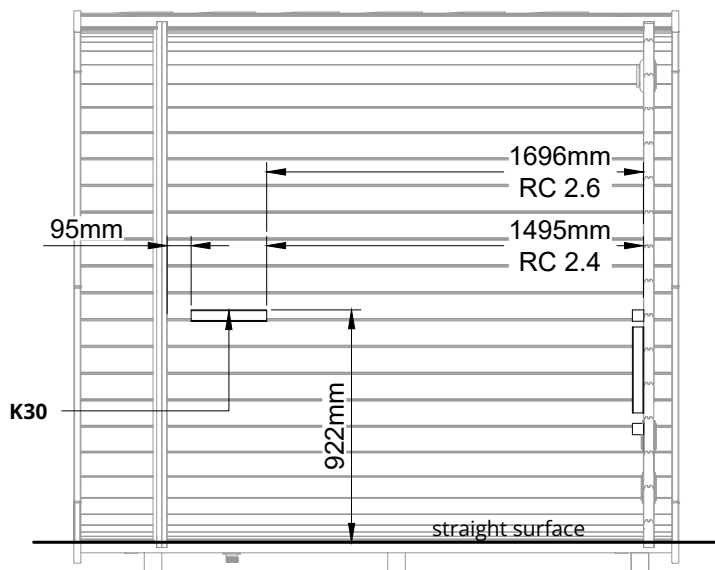

S5	Screws 4,5x60 for Spruce Screws 4,2x55 for Thermo	x2
S7	Screws 4,5x80 for Spruce Screws 4,2x75 for Thermo	x6
		

NB! use a level

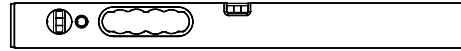

Notice!

Drill 4mm hole in the K10 square wood before screwing.

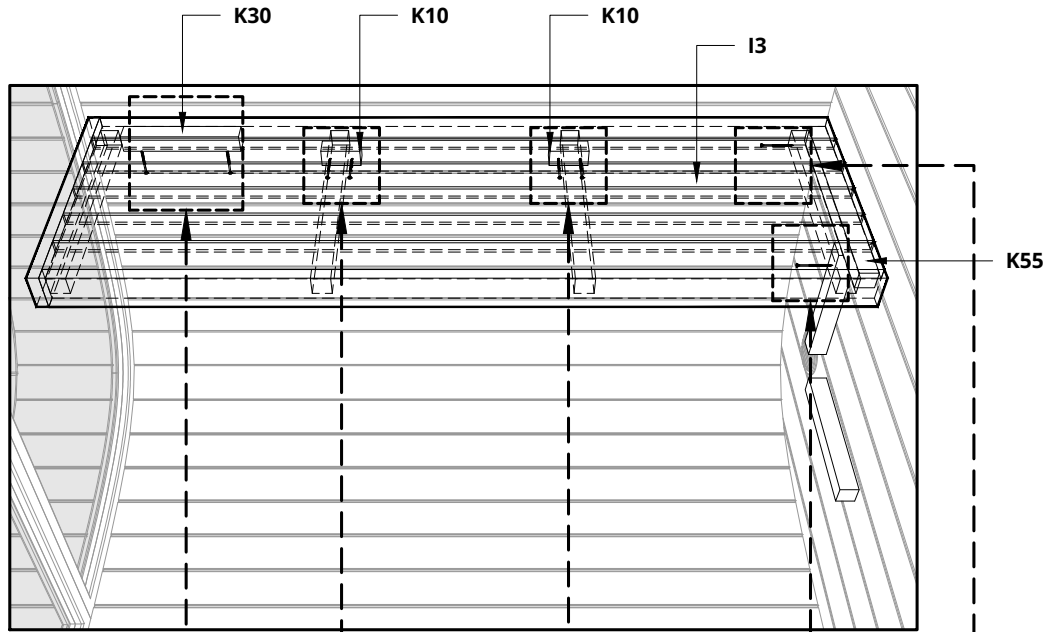
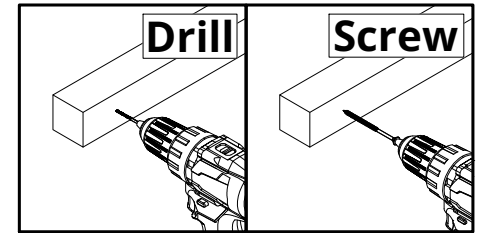



Install and fix the I3 upper bench to the wall mounts K55 with two S7 screws and K30 with two S5 screws.

Install some aids to keep the bench level.

Once the upper bench is attached, K10 must be installed next. K10 must be installed at the lower edge of the square wood attached under the bench and fixed to the side wall with two S7 screws. Locations are shown in the pictures.

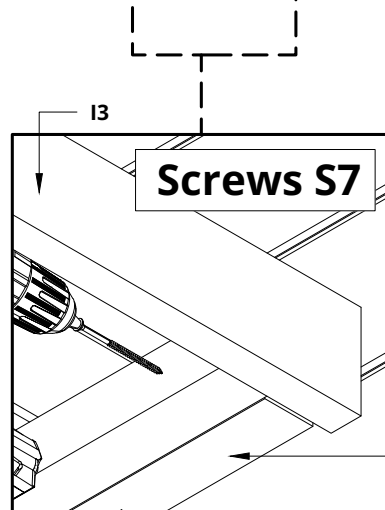
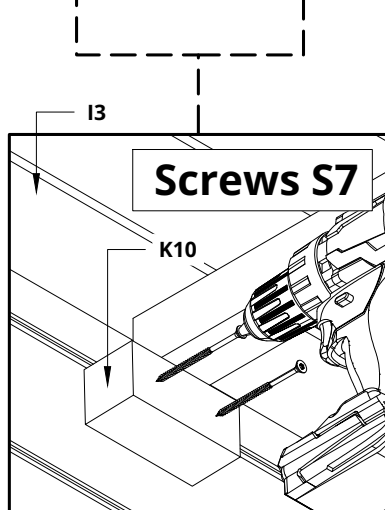
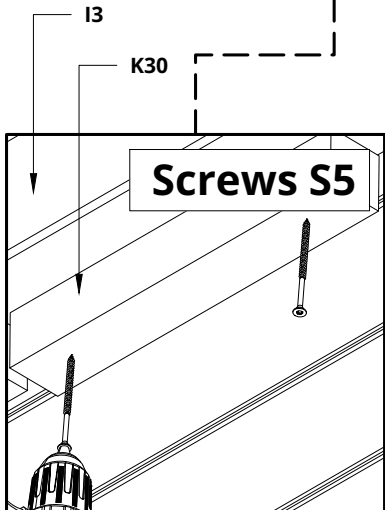
Before installing square wood K10, drill holes for screws. Add glue and then screw it to the wall and wipe off the excess glue.



S5	Screws 4,5x60 for Spruce Screws 4,2x55 for Thermo	x4
		

NB! use a level

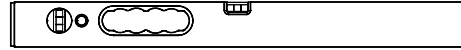

Notice!

Drill 4mm hole in the K.. square woods before screwing.

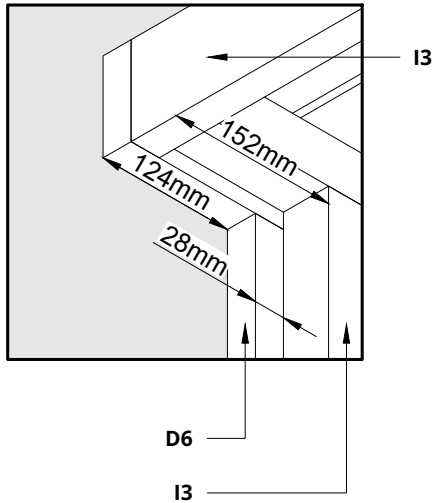
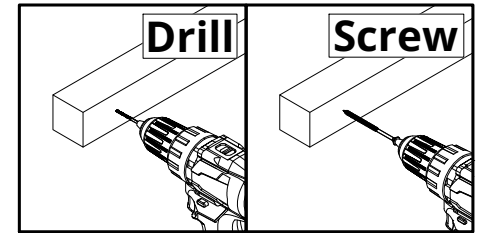

The measurement must be started from the lower edge of the square wood attached under the bench for square wood legs.
The square wood and cover board are longer, they must be cut to the correct size.
Please countersink the screw head!

Before installation, mark the distance of the square wood K90 from the outer edge of the bench. Measure from bench I3 down to the floor. Cut the K90 to size. If it is cut correctly, make sure that square wood K90 stays perpendicular to the bench when attaching it.

Before installing the cover board D6, mark the distance from the outer edge of the bench.

Measure from the marked point down to the floor. Cut the D6 cover board to size. If it is cut to size, fasten with two S5 screws.

Make sure that cover board D6 stays perpendicular to the bench and in parallel with K90 when attaching it to K90.

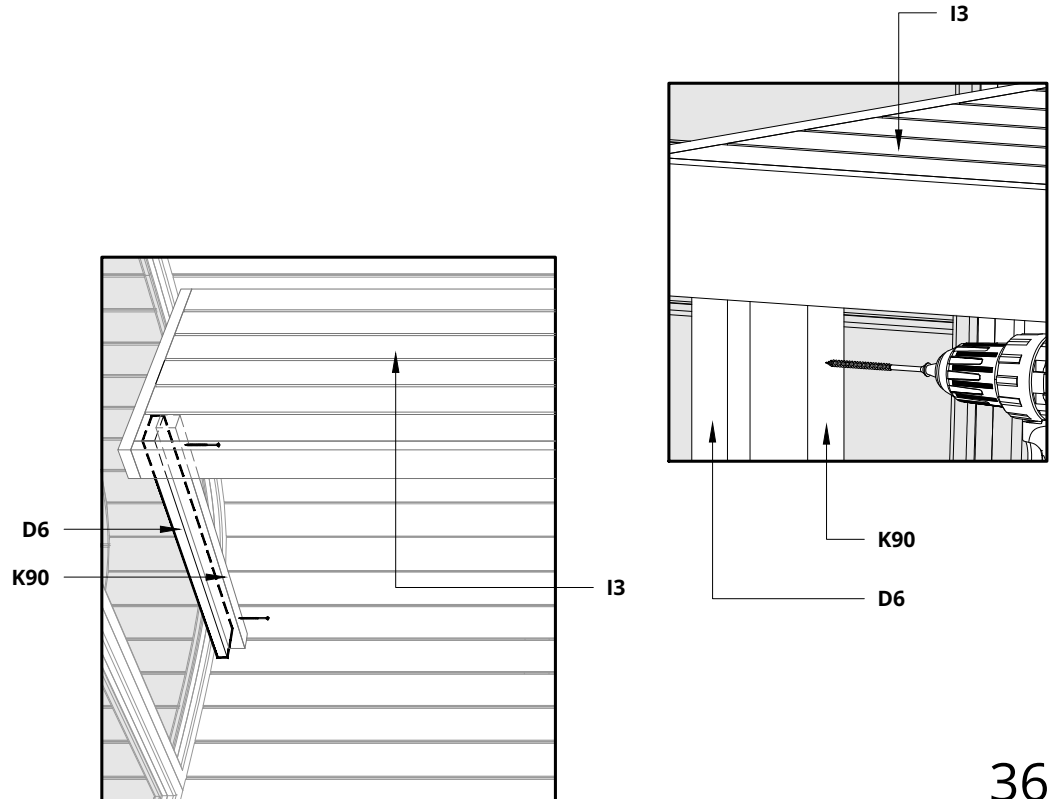
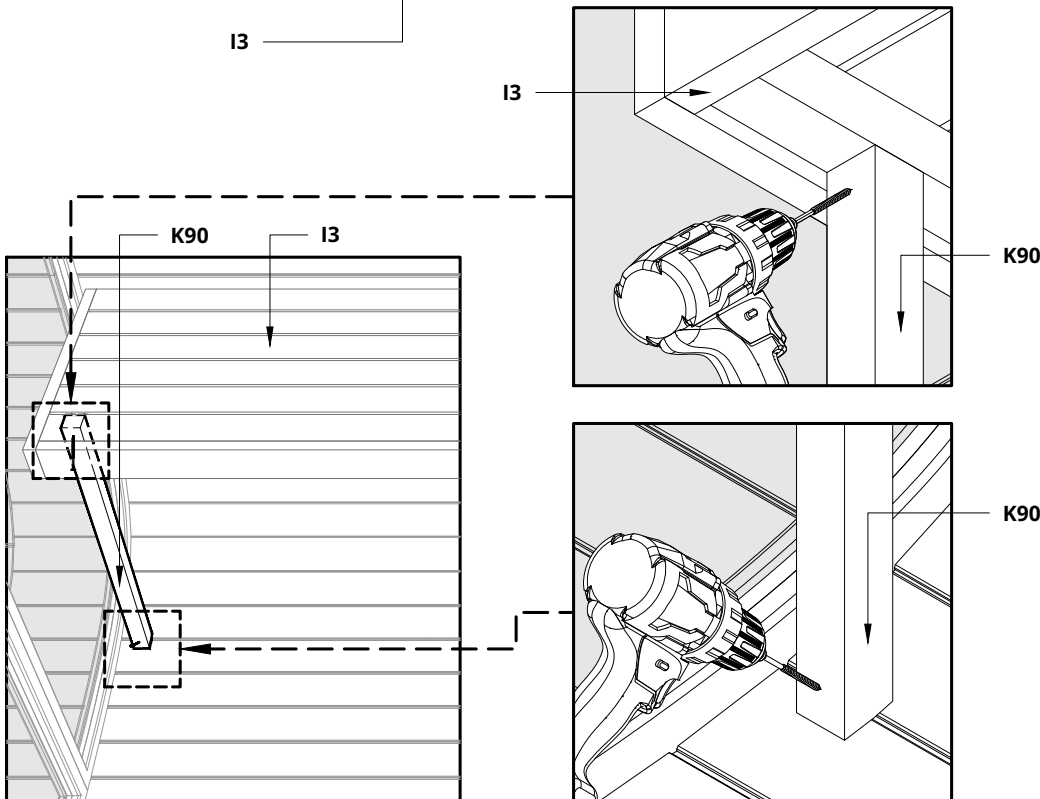

S5	Screws 4,5x60 for Spruce Screws 4,2x55 for Thermo	x2
S7	Screws 4,5x80 for Spruce Screws 4,2x75 for Thermo	x3
		

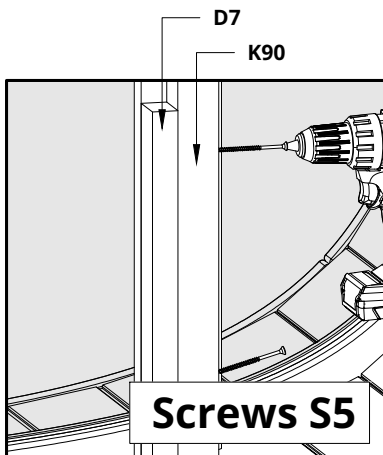
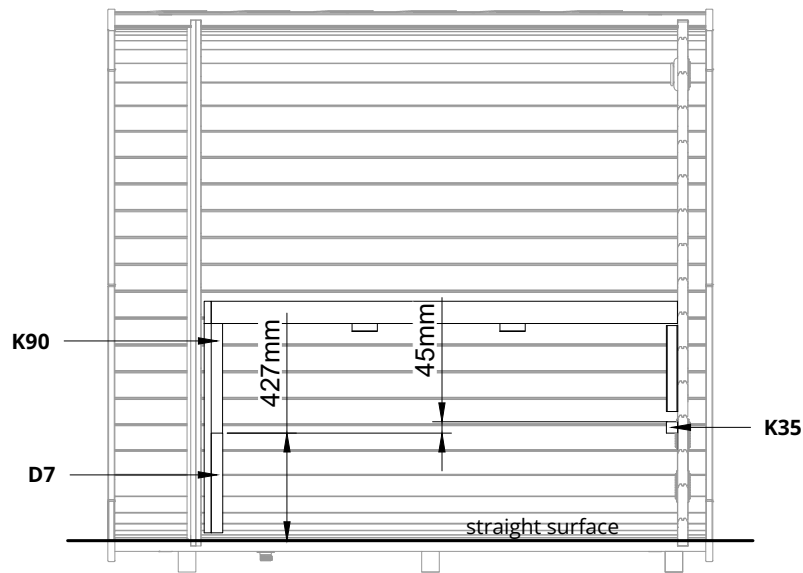
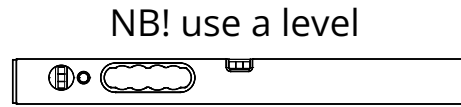

The cover board is longer, it must be cut to the correct size.
Height measurements are measured from a straight surface.

First install cover board piece D7. Mark the upper edge of D7 cover board piece.

Measure from the marked point to the floor to get the measurement. Cut the D7 cover board piece to size.

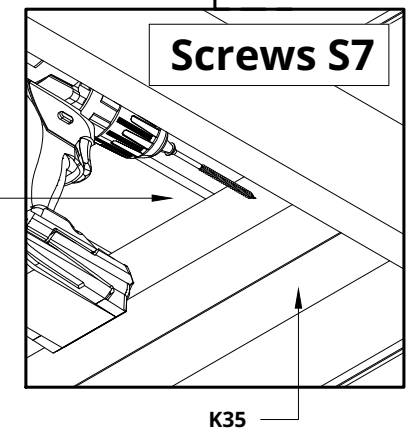
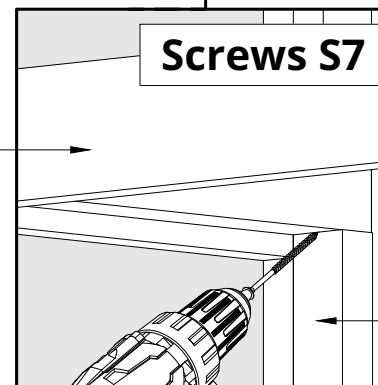
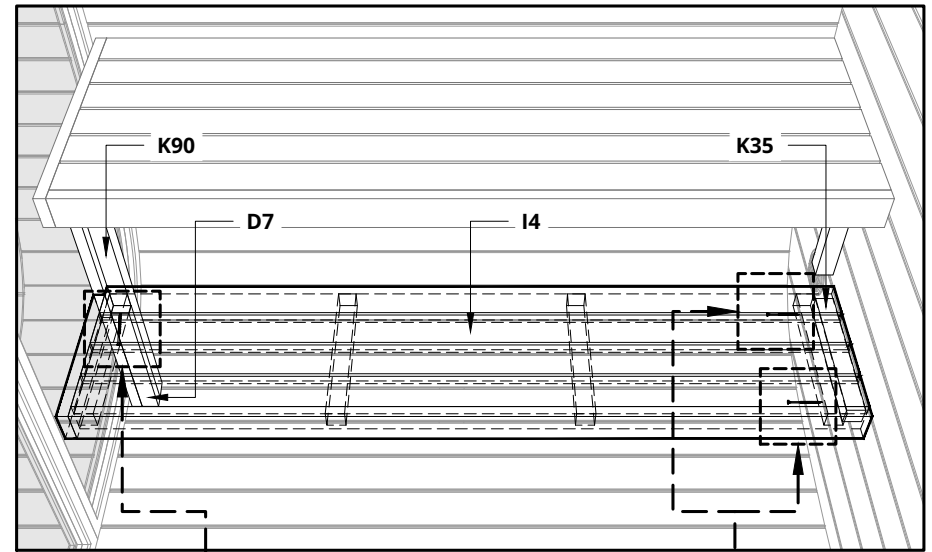

Attach the D7 cover board piece to K90 square wood with two S5 screws.

Now install and fix the I4 bench to the wall mounts K35 with two S7 screws and to K90 with one S7 screw.

Install an aid to keep the bench level.

S5	Screws 4,5x60 for Spruce Screws 4,2x55 for Thermo	x10
		

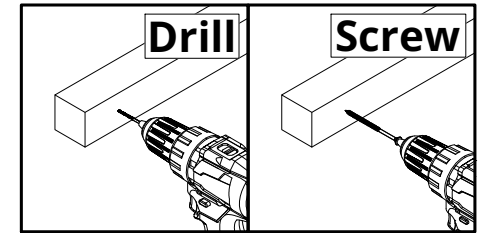
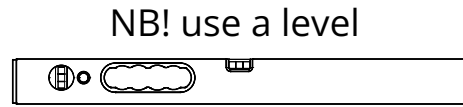

Notice!

Drill 4mm hole in the K.. square woods before screwing.

*The measurement must be started from the lower edge of the square wood attached under the bench.
The square wood and cover board are longer, they must be cut to the correct size.*

Please countersink the screw heads that are hidden behind the other part!

First measure and install the corner leg K45 of the middle bench I4. Measure from the bench to the floor. Cut the K45 to size. If it is cut correctly, make sure that square wood K45 stays perpendicular to the bench when attaching it.

Next, install the two middle legs K45 of the middle bench I4. Measure from the bench to the floor. Cut the K45 to size. If it is cut correctly, make sure that square wood K45 stays perpendicular to the bench when attaching it.

Now install cover boards D7 on the middle legs K45. Measure from the bench to the floor. Cut the D7 to size and install to the K45 legs with two screws each as shown in the picture.

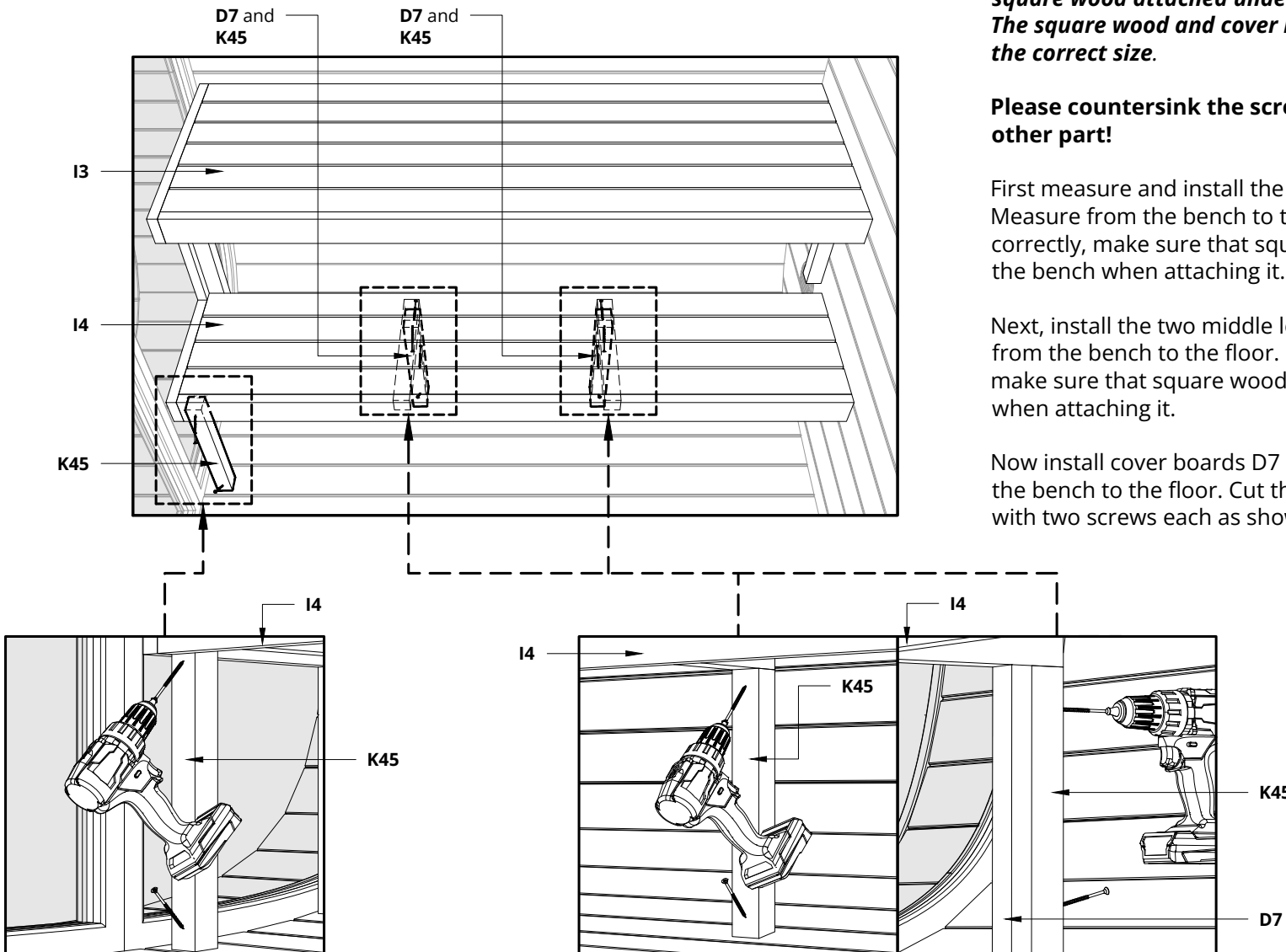

S5	Screws 4,5x60 for Spruce Screws 4,2x55 for Thermo	x8

NB! use a level

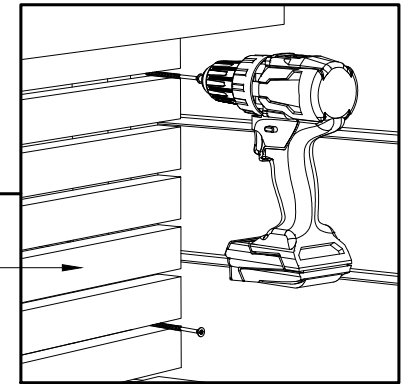
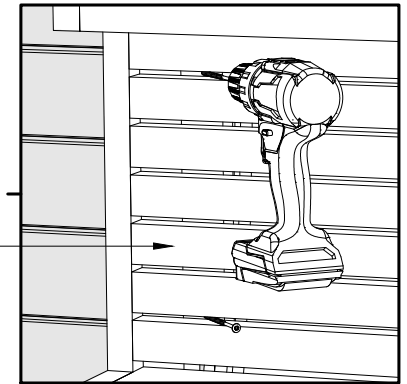
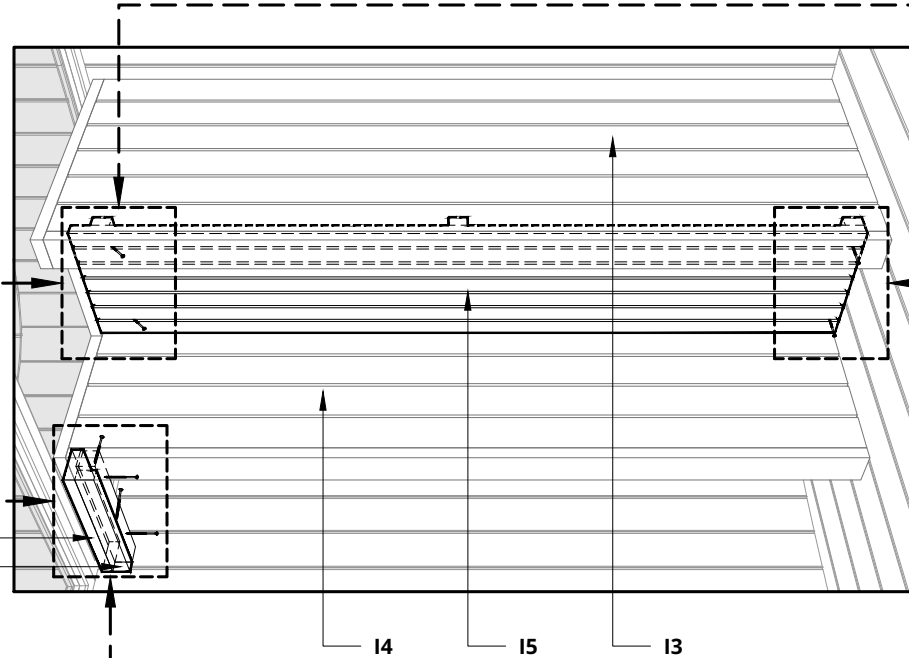
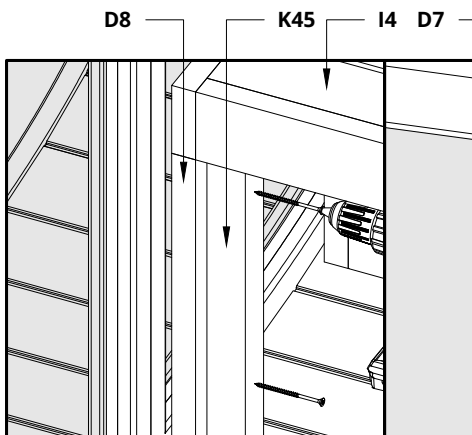
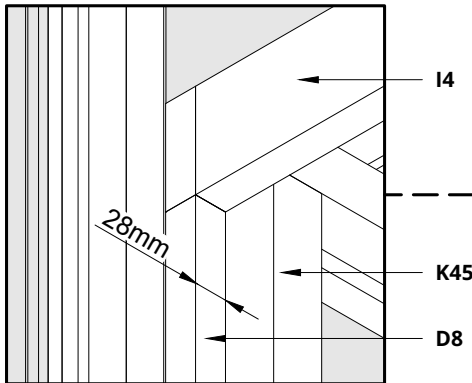
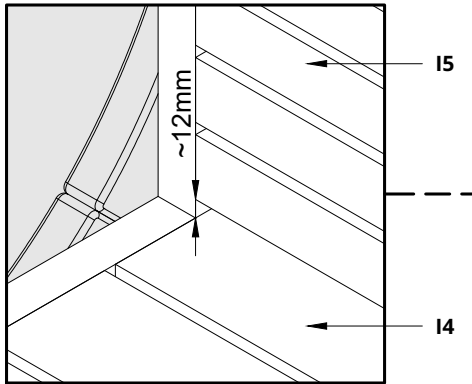
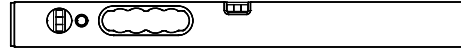

The cover board are longer, they must be cut to the correct size.

First measure and install the corner leg K45 cover boards D7 and D8. Measure from the bench to the floor. Cut the D7 and D8 to size. First install cover board D7 and then D8. Both are attached with two screws to the corner leg **K45 square wood**.

Next install the bench skirt I5. It must be placed so that there is a small gap between the lower edge and the middle bench I4. Fasten with four screws.

S5	Screws 4,5x60 for Spruce Screws 4,2x55 for Thermo	x6
S7	Screws 4,5x80 for Spruce Screws 4,2x75 for Thermo	x6
		

NB! use a level



Notice!

Drill 4mm hole in the K.. square woods before screwing.

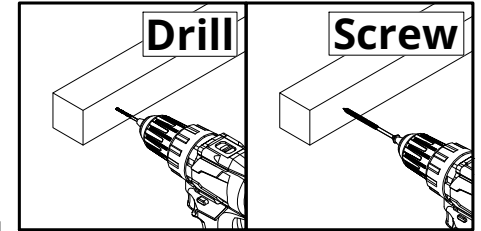

RC - Round Cube

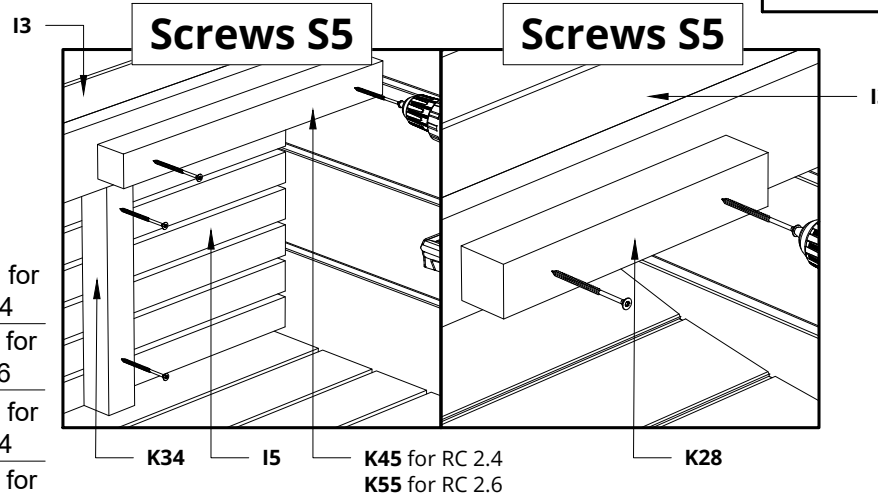
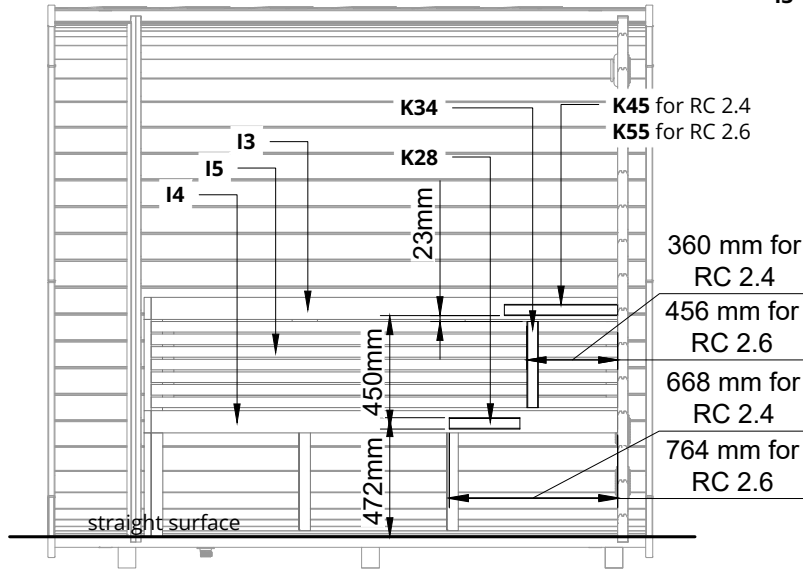

Height measurements are measured from a straight surface. Please countersink the screw head!

First measure and install wall mount K28. Measure the height and distance from the back wall. The upper edge height and distance from the back wall of K28 is shown in the picture.

Next measure and install K45 for RC 2.4 or K55 for RC 2.6. Measure the upper edge of the wall mount from the wall mount K28 and the distance from the back wall.

Next measure and install bench skirt wall mount K34. Measure the upper edge from the wall mount K45 for RC 2.4 or K55 for RC 2.6 of the wall mount K34 and the outer edge distance from back wall. The K34 wall mount should be perpendicular to the K45 for RC 2.4 or K55 for RC 2.6 wall mount.

Before installing square wood K28, K34, and K45 for RC2.4 or K55 for RC2.6, drill holes for screws. Add glue and then screw it to the wall and wipe off the excess glue.

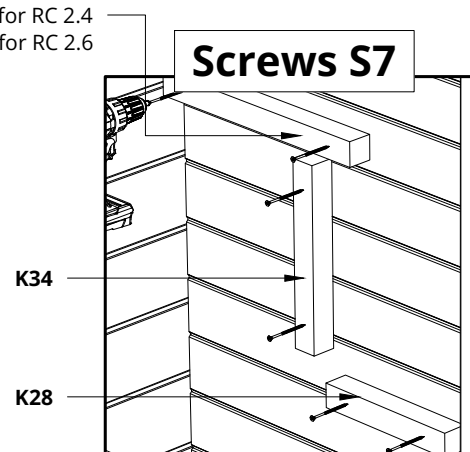
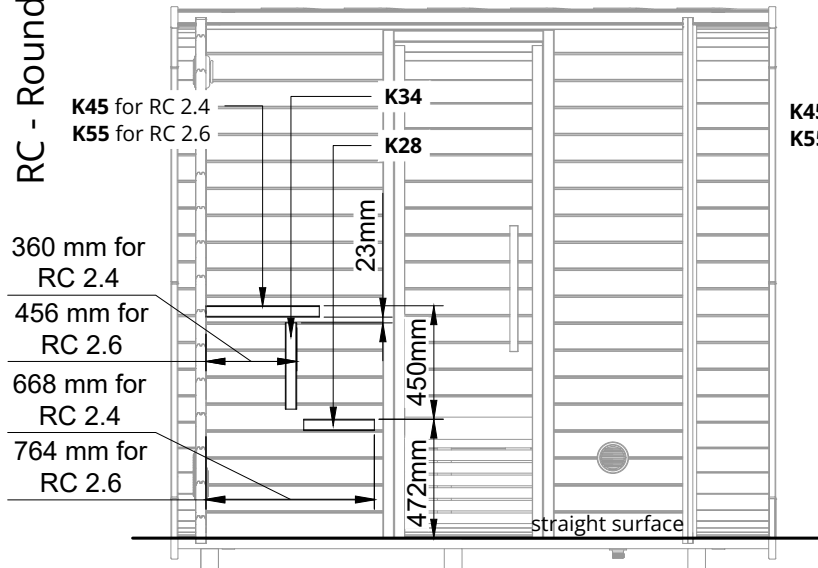

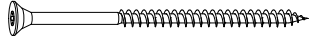
S7	Screws 4,5x80 for Spruce Screws 4,2x75 for Thermo	x10
		

Notice!

Drill 4mm hole in the K10 square wood before screwing.

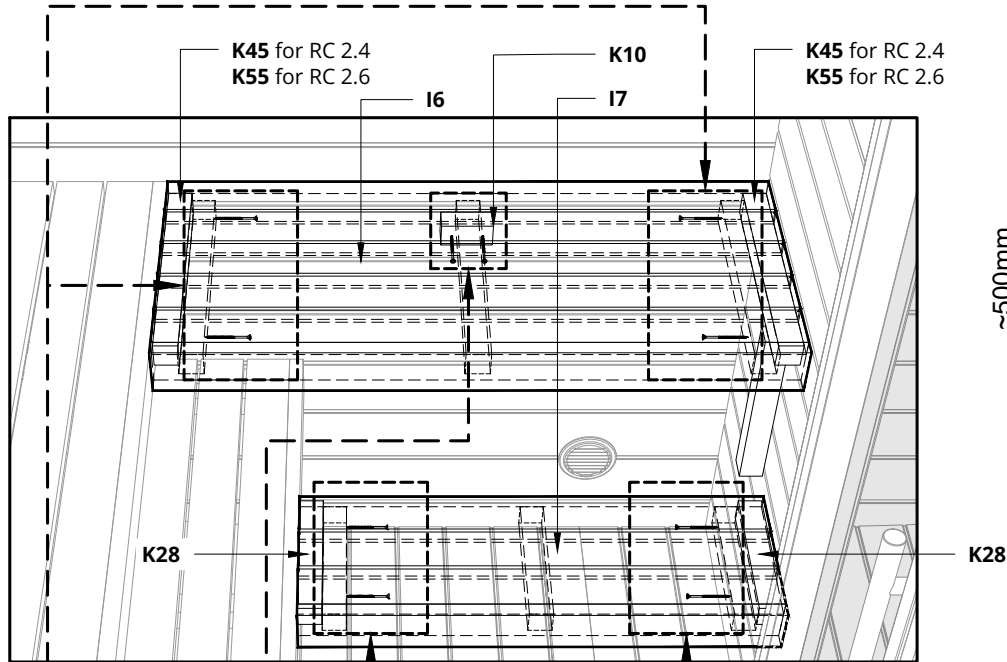
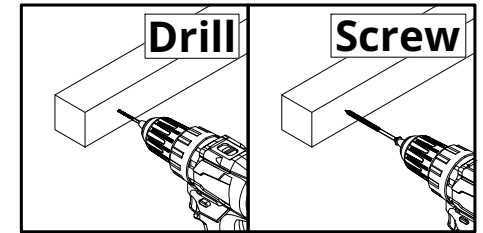

RC - Round Cube

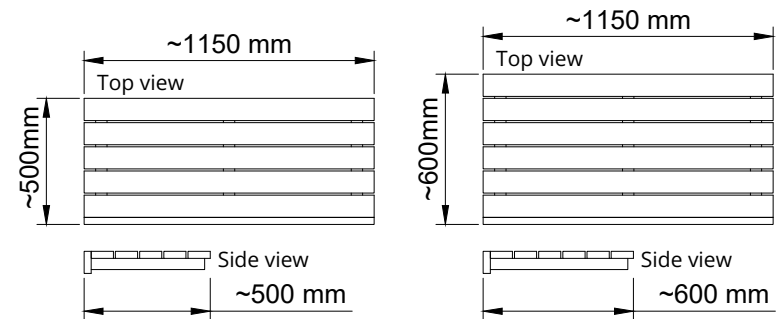

For Round Cube 2.4

For Round Cube 2.6

First install and fix the I6 upper bench to the K45 for RC 2.4 or K55 for RC 2.6 mounts with two screws.

If the upper bench is attached, K10 must be installed next. K10 must be installed at the lower edge of the square wood attached under the bench and fixed to the back wall with two screws. Locations are shown in the pictures.

Now install and fix the I7 bench to the wall mounts K28 with two screws.

Before installing square wood K10, drill holes for screws. Add glue and then screw it to the wall and wipe off the excess glue.

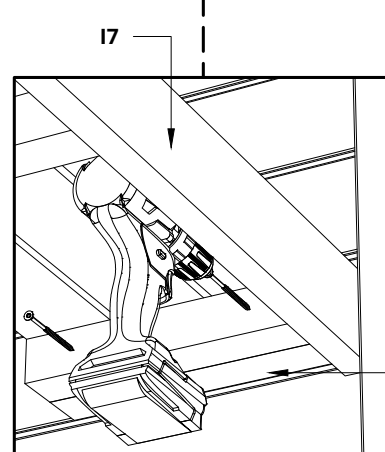
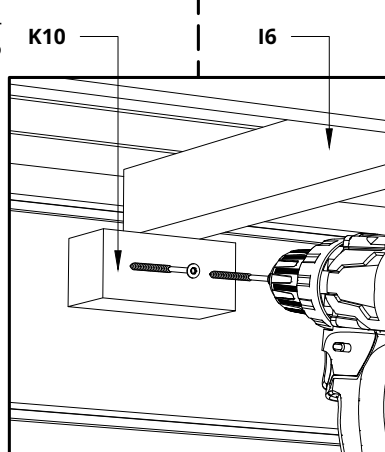
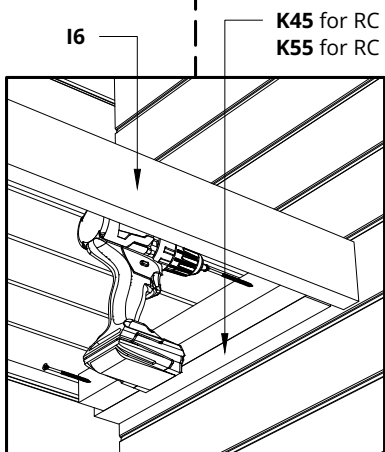

S1	Screws 3x30	x4
S5	Screws 4,5x60 for Spruce Screws 4,2x55 for Thermo	x2
		

To install the cover strip, use screws (which are included) or use lath nails (which are not included, you have to provide them yourself).

The best result is obtained with nails, their heads are less visible.

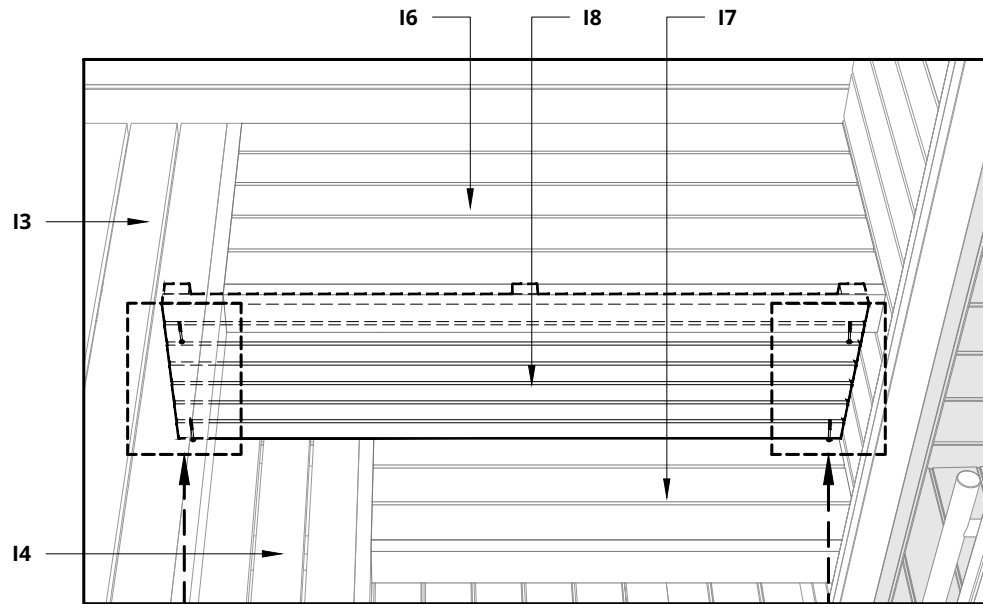
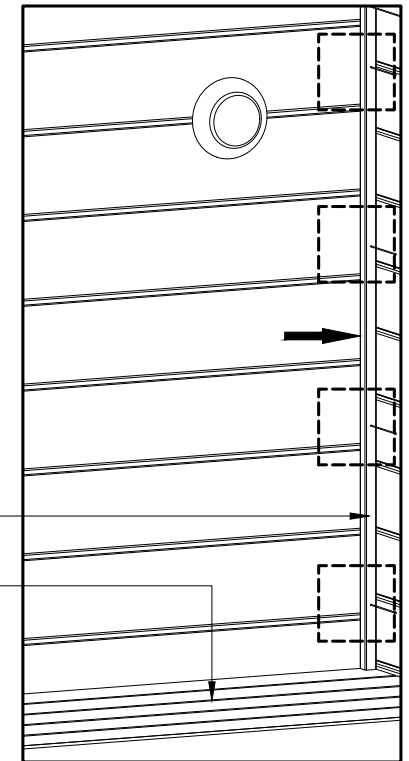
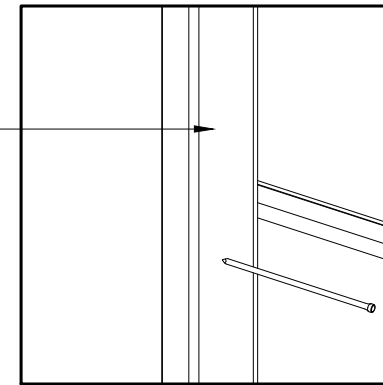

The cover strip is longer, it must be cut to the correct size.

Please countersink the screw head when using screws for cover strip!

When you use screws, it is necessary to drill small holes before screwing the cover strips, so that they do not split.

D3 is fixed with 4 screws or with 4 lath nails to the middle wall.

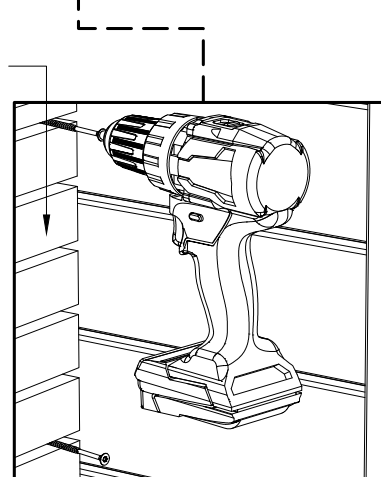
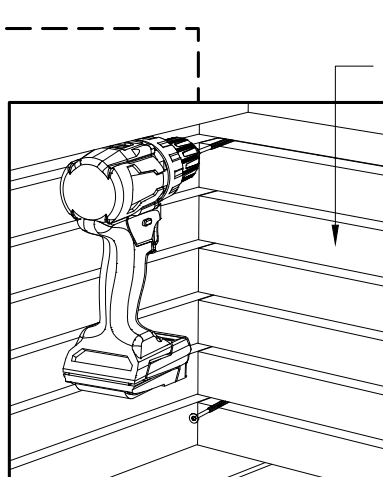
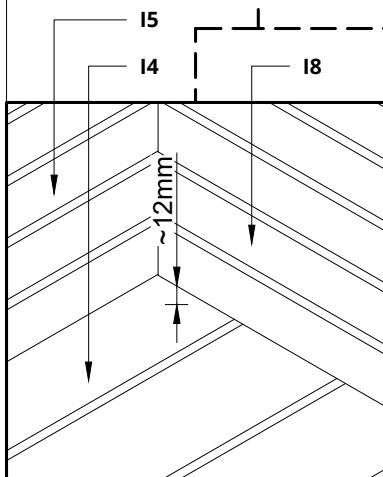

Install the bench skirt 18. It must be placed so that there is a small gap between the lower edge and the middle bench 14 and 17. Fasten with four screws.

S2	Screws 3x40	x3
S5	Screws 4,5x60 for Spruce Screws 4,2x55 for Thermo	x6
		

NB! use a level

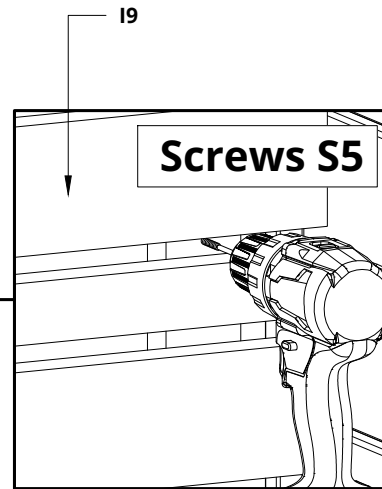
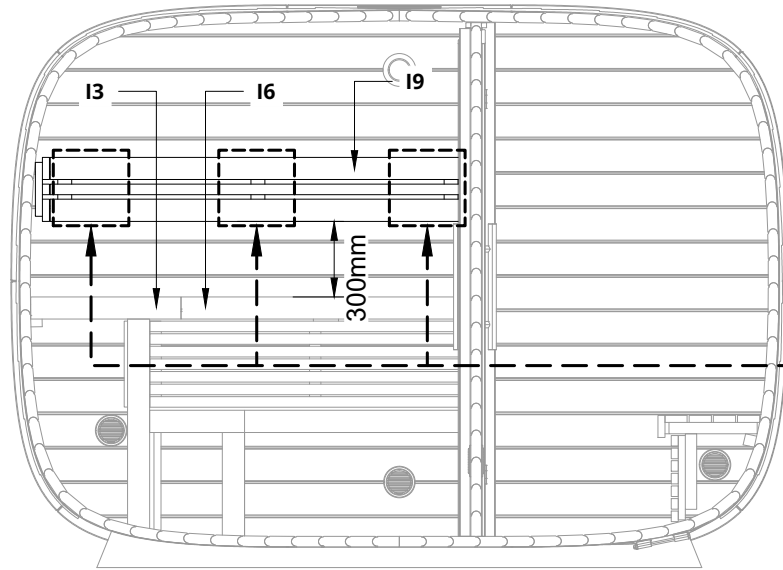
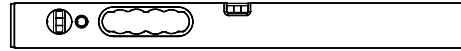

The height of the lower edge of the backrest is shown in the picture.

First install the bench backrest 19 and fasten with three screws S5. The height of the lower edge of the backrest is shown in the picture.

Next install the bench backrest 110. It needs to be set from the bottom edge as the wall is not flat. For leveling, use S2 screws, putting them behind the block with which the backrests are against the wall. At the beginning, screw the screws in, leaving 20 mm out, then, if necessary, turn them inward or outward. Or use spacer blocks.

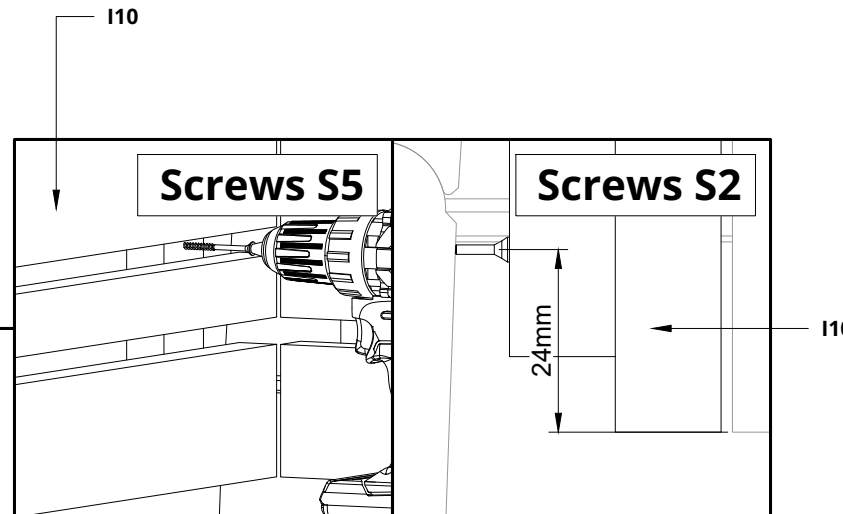
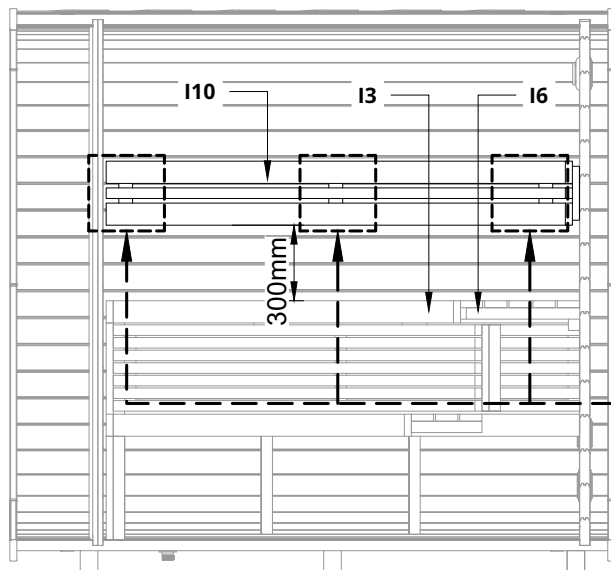

S5	Screws 4,5x60 for Spruce Screws 4,2x55 for Thermo	x3
		

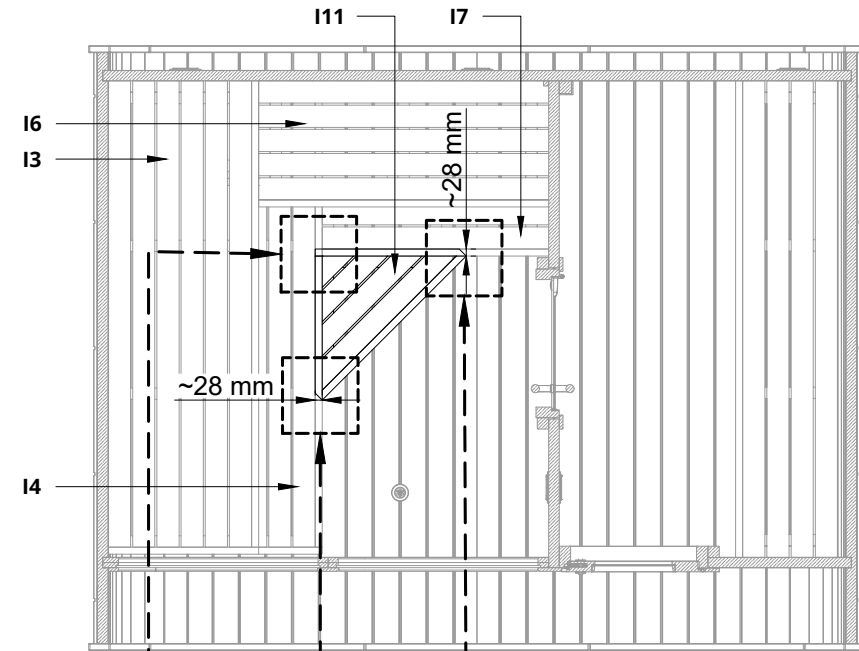
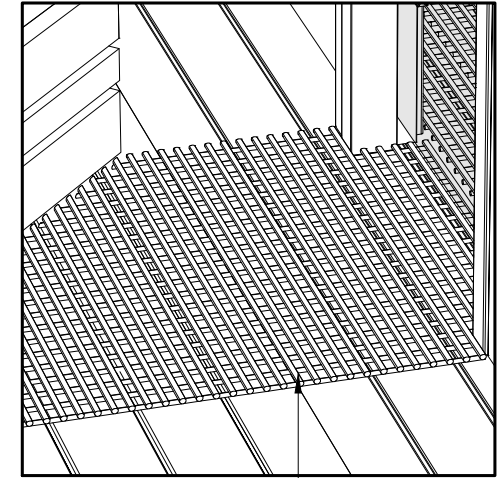
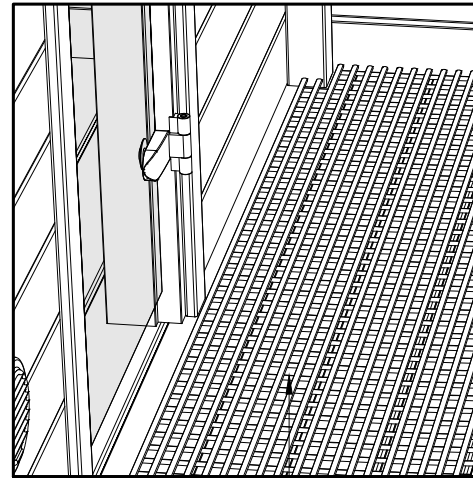

I12

I13

Install the ladder so that its rear edges are 28 mm below the edges of the middle benches.
Attach it to the floor with three screws, the attachment points are shown in the picture.

If the ladder is in place, place the floor mats.

I11

I11

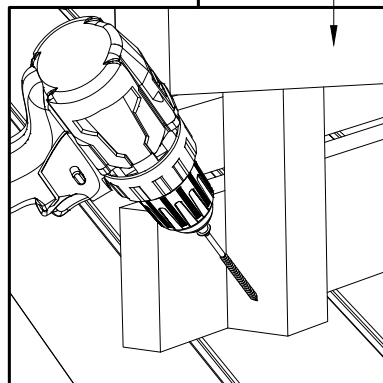
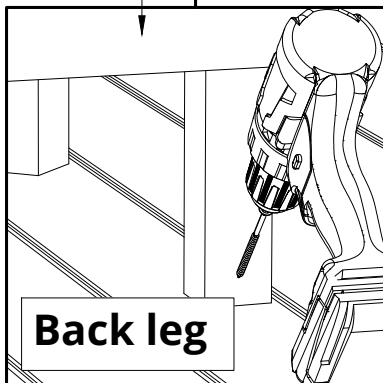

I11

